

10/100BASE-TX/FX Mini- Φ ™ Transceiver

GENERAL DESCRIPTION

The BCM5221 is a single channel, low-power, 10/100BASE-TX/FX transceiver targeting a number of applications requiring intelligent power management and robust network tolerance. The BCM5221 operates at 3.3V or 2.5V. The devices contain a full-duplex 10BASE-T/100BASE-TX/100BASE-FX Fast Ethernet transceiver, which performs all of the physical layer interface functions for 10BASE-T Ethernet on CAT 3, 4, and 5 unshielded twisted pair (UTP) cable and 100BASE-TX Fast Ethernet on CAT 5 UTP cable. In addition, layout compatibility with the previous generation BCM5201 shortens the design cycle for the BCM5221. 100BASE-FX is supported through the use of external fiber-optic transmit and receive devices.

The BCM5221 is a highly integrated solution combining a digital adaptive equalizer, ADC, phase lock loop, line driver, encoder, decoder and all the required support circuitry into a single monolithic CMOS chip. It complies fully with the IEEE 802.3u specification, including the Media Independent Interface (MII) and Auto-Negotiation subsections.

The effective use of digital technology in the BCM5221 design results in robust performance over a broad range of operating scenarios. Problems inherent to mixed-signal implementations, such as analog offset and on-chip noise, are eliminated by employing field proven digital adaptive equalization and digital clock recovery techniques.

FEATURES

- Power supply: 2.5V or 3.3V
- Integrated voltage regulator to allow operation from a single supply source
- Power consumption: <275 mW
- Unique energy detection circuit to enable intelligent power management
- HP auto-MDIX
- Cable length indication
- Cable noise level indication
- Robust CESD tolerance
- Cable length greater than 140 meters
- Well under 10 PPM defect ratio quality
- +/-10% voltage tolerance
- Industrial temperature range (-40 to 85C)
- MII and RMII configurable
- IEEE 1149.1 (JTAG) scan chain support
- MII management via serial port
- Layout-compatible with BCM5201
- 10BASE-T/100BASE-TX/FX IEEE 802.3u fast Ethernet transceiver
- Glueless TX-to-FX media conversion
- 64-pin TQFP or 64-pin BGA package

APPLICATIONS

- PCMCIA/CardBus cards
- LAN on motherboard
- IP phones
- Cable modems
- Set-top boxes and print servers
- Wireless access points
- Embedded telecom

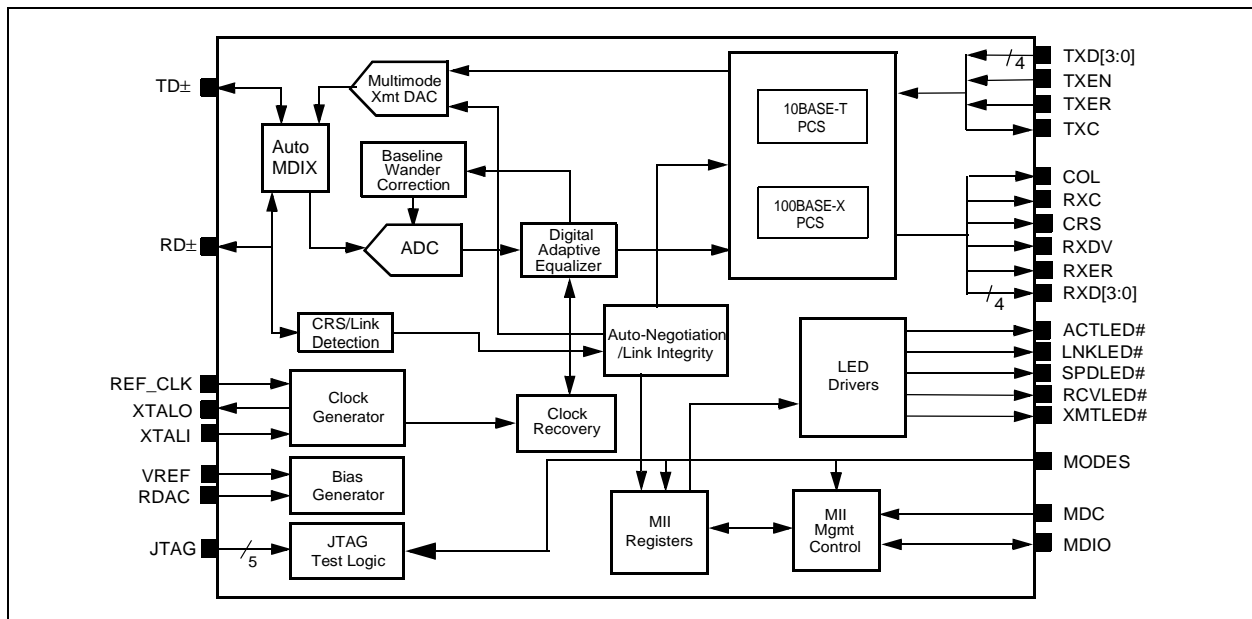

Functional Block Diagram

REVISION HISTORY

Revision	Date	Change Description
5221-DS02-R	2/03/00	Initial Release
5221-DS03-R	4/28/00	<ol style="list-style-type: none"> 1. Added BGA pin designations on Table 3. 2. Added BGA Pinout Diagram on page 11. 3. Added Low-Power modes on page 16. 4. Eliminated XTALVDD references from various pages. 5. Added BIASVDD to Table 55 on page 61. 6. Added further explanations to XTALI, XTALO and REF_CLK pins descriptions to Table 3 on page 6.
5221-DS04-R	6/19/00	<p>Changed Advanced Specifications to Preliminary Specifications. Minor text changes.</p> <ul style="list-style-type: none"> • Deleted CK25 from PHYAD4 - Page 9, 12, and 13. • Removed TXDAC Power Mode bit from MII register 18h bit 8, Table 7 on page 19. • Changed default value of MII Register 1Ah, Table 7 on page 20. • Added bit 15, FDX LED Enable, to MII register 1Ah, Table 25. • Changed 0 to MDIX_DIS pin for the default value of MII register 1Ch, bit 11, in Table 27. • Fixed several register definitions and moved them to the correct tables. • Added timing and power values to parameters in Table 40 through Table 57. • Added Thermal Characteristics section on page 66. • Updated Table 57, Electrical Characteristics (Supply Current TYP from 95-110 mA). • Updated Pin Label descriptions for XTALI/XTALO and ENERGY_DET in Table 3, on pages 7 and 10 respectively. • Updated "PHY Identifier Registers" section by changing "00h" to "0h" in the paragraph under Table 11 on page 26. • Updated descriptions for LEDs H8 and G8 in Table 3, Pin Descriptions, on page 10.
5221-DS05-R	02/14/01	<ul style="list-style-type: none"> • Deleted CK25 from PHYAD4 - Page 9, 12, and 13. • Removed TXDAC Power Mode bit from MII register 18h bit 8, Table 7 on page 19. • Changed default value of MII Register 1Ah, Table 7 on page 20. • Added bit 15, FDX LED Enable, to MII register 1Ah, Table 25. • Changed 0 to MDIX_DIS pin for the default value of MII register 1Ch, bit 11, in Table 27. • Fixed several register definitions and moved them to the correct tables. • Added timing and power values to parameters in Table 40 through Table 57. • Added Thermal Characteristics section on page 66. • Updated Table 57, Electrical Characteristics (Supply Current TYP from 95-110 mA). • Updated Pin Label descriptions for XTALI/XTALO and ENERGY_DET in Table 3, on pages 7 and 10 respectively. • Updated "PHY Identifier Registers" section by changing "00h" to "0h" in the paragraph under Table 11 on page 26. • Updated descriptions for LEDs H8 and G8 in Table 3, Pin Descriptions, on page 10.
5221-DS06-R	05/29/01	<ul style="list-style-type: none"> • Clarified power-on reset requirement on page 14, 17, and 49.
5221-DS07-R	11/18/02	<ul style="list-style-type: none"> • Updated Figure 1, "BCM5221KPB Ballout Diagram," on page 12. • Modified description for "Loopback Mode" on page 14. • Added "HP Auto-MDIX" on page 19. • Modified description for "MII Register Map Summary" on page 22. • XTALI Rise/Fall Time has been removed from Table 38 on page 59. • Updated Table 40 on page 60. • Added "Reserved" note where applicable, and modified descriptions.

Broadcom Corporation
 P.O. Box 57013
 16215 Alton Parkway
 Irvine, California 92619-7013
 © Copyright 2002 by Broadcom Corporation
 All rights reserved
 Printed in the U.S.A.

Broadcom[®], and the pulse logo[®], and Connecting Everything[™] are trademarks of Broadcom Corporation and/or its subsidiaries in the United States and certain other countries. All other trademarks are the property of their respective owners.

TABLE OF CONTENTS

Section 1: Functional Description	1
Overview	1
Encoder/Decoder	1
Link Monitor	2
Carrier Sense	2
Collision Detection	2
Auto-Negotiation	2
ADC	3
Digital Clock Recovery/Generator	3
Baseline Wander Correction	3
Multimode Transmit DAC	3
Far-End Fault	4
RMII Interface	4
Section 2: Hardware Signal Definitions	7
Section 3: Pinout Diagram	12
Section 4: Operational Description	14
Reset	14
Isolate Mode	14
Super Isolate Mode	14
Loopback Mode	14
Full-Duplex Mode	15
100BASE-FX Mode	15
10BASE-T Mode	15
10BASE-T Serial Mode	16
Special LED Modes	16
Interrupt Mode	17
Energy Detection	17
Auto Power Down Mode	18
HP Auto-MDIX	19



Section 5: Register Summary	20
Media Independent Interface (MII) Management Interface: Register Programming	20
MII Register Map Summary	22
MII Control Register	25
MII Status Register	27
PHY Identifier Registers	29
Auto-Negotiation Advertisement Register	30
Auto-Negotiation Link Partner (LP) Next Page Transmit Register	35
100BASE-X Auxiliary Status Register	38
100BASE-X Receive Error Counter	40
100BASE-X Disconnect Counter	41
Auxiliary Control/Status Register	42
Auxiliary Mode 2 Register	46
10BASE-T Auxiliary Error & General Status Register	48
Auxiliary Mode Register	50
Auxiliary Multiple PHY Register	51
Broadcom Test Register	53
Auxiliary Mode 4 Register (Shadow Register)	54
Auxiliary Status 2 Register (Shadow Register)	55
Auxiliary Status 3 Register (Shadow Register)	56
Auxiliary Mode 3 Register (Shadow Register)	57
Auxiliary Status 4 Register (Shadow Register)	58
Section 6: Timing and AC Characteristics	59
Section 7: Electrical Characteristics	75
Section 8: Application Example	77
Section 9: Thermal Characteristics	78
Section 10: Mechanical Information	79
Section 11: Ordering Information	81



LIST OF FIGURES

Figure 1: BCM5221KPB Ballout Diagram.....	12
Figure 2: BCM5221KPT Pin Diagram.....	13
Figure 3: Clock and Reset Timing	60
Figure 4: MII Transmit Start of Packet Timing (100BASE-TX)	61
Figure 5: MII Transmit End of Packet Timing (100BASE-TX)	61
Figure 6: MII Receive Start of Packet Timing (100BASE-TX)	63
Figure 7: MII Receive End of Packet Timing (100BASE-TX)	63
Figure 8: MII Receive Packet Premature End (100BASE-TX)	64
Figure 9: MII Link Failure or Stream Cipher Error During Receive Packet.....	64
Figure 10: MII False Carrier Sense Timing (100BASE-TX).....	65
Figure 11: MII 10BASE-T Transmit Start of Packet Timing.....	66
Figure 12: 10BASE-T Serial Transmit Timing	68
Figure 13: 10BASE-T Serial Receive Timing	69
Figure 14: Management Interface Timing.....	71
Figure 15: Management Interface Timing (with Preamble Suppression On).....	71
Figure 16: RMII Transmit Packet Timing.....	72
Figure 17: RMII Receive Packet Timing	73
Figure 18: Power Connections BCM5221 (3.3V)	77
Figure 19: 64-Pin TQFP 10mm Package (BCM5221 KPT)	79
Figure 20: FBGA 64, 8mmx8mm (BCM5221 KPB)	80



LIST OF TABLES

Table 1: 4B5B Encoding.....	5
Table 2: Receive Error Encoding.....	6
Table 3: Pin Descriptions.....	7
Table 4: 10BASE-T Serial Mode (7-Wire) Signals.....	16
Table 5: Low Power Modes	18
Table 6: MII Management Frame Format.....	20
Table 7: MII Register Map Summary	22
Table 8: MII Shadow Register Map Summary	24
Table 9: MII Control Register (Address 00000b, 0d, 00h)	25
Table 10: MII Status Register (Address 00001B, 01d, 01h).....	27
Table 11: PHY Identifier Registers (Addresses 00010 and 00011b, 02 and 03b, 02 and 03h).....	29
Table 12: Auto-Negotiation Advertisement Register (Address 04d, 04h).....	30
Table 13: Auto-Negotiation Link Partner Ability Register (Address 05d, 05h).....	32
Table 14: Auto-Negotiation Expansion Register (Address 00110b, 6d, 06h).....	33
Table 15: Next Page Transmit Register (Address 07d, 07h).....	34
Table 16: Next Page Transmit Register (Address 08d, 08h).....	35
Table 17: 100-BASE-X Auxiliary Control Register (Address 16d, 10h).....	36
Table 18: 100BASE-X Auxiliary Status Register (Address 17d, 11h).....	38
Table 19: 100BASE-X Receive Error Counter (Address 18d, 12h).....	40
Table 20: 100BASE-X False Carrier Sense Counter (Address 19d, 13h).....	41
Table 21: 100BASE-X Disconnect Counter (Address 20d, 14h).....	41
Table 22: PTEST Register (Address 10111b, 23d, 17h).....	42
Table 23: Auxiliary Control/Status Register (Address 24d, 18h).....	42
Table 24: Auxiliary Status Summary Register (Address 25d, 19h).....	44
Table 25: Interrupt Register (Address 26d, 1Ah).....	45
Table 26: Auxiliary Mode 2 Register (Address 27d, 1Bh).....	46
Table 27: 10BASE-T Auxiliary Error & General Status Register (Address 28d, 1Ch).....	48
Table 28: Auxiliary Mode Register (Address 29d, 1Dh).....	50
Table 29: Auxiliary Multiple PHY Register (Address 30d, 1Eh).....	51
Table 30: Broadcom Test (Address 31d, 1Fh).....	53
Table 31: Auxiliary Mode 4 Register (Shadow Register 26d, 1Ah).....	54
Table 32: Auxiliary Status 2 Register (Shadow Register 27d, 1Bh).....	55

Table 33: Cable Length.....	55
Table 34: Auxiliary Status 3 Register (Shadow Register 28d, 1Ch).....	56
Table 35: Auxiliary Mode 3 Register (Shadow Register 29d, 1Dh).....	57
Table 36: Current Receive FIFO Size.....	57
Table 37: Auxiliary Status 4 Register (Shadow Register 30d, 1Eh).....	58
Table 38: Clock Timing.....	59
Table 39: Reset Timing.....	59
Table 40: MII 100BASE-X Transmit Timing.....	60
Table 41: MII 100BASE-X Receive Timing.....	62
Table 42: MII 10BASE-T Transmit Timing.....	66
Table 43: MII 10BASE-T Receive Timing.....	67
Table 44: MII 10BASE-T Collision Timing.....	67
Table 45: 10BASE-T Serial Transmit Timing.....	68
Table 46: 10BASE-T Serial Receive Timing.....	69
Table 47: Loopback Timing (MII).....	70
Table 48: Auto-Negotiation Timing.....	70
Table 49: LED Timing.....	70
Table 50: Management Data Interface Timing.....	71
Table 51: RMII Transmit Timing.....	72
Table 52: RMII Receive Timing.....	73
Table 53: RMII 100BASE-X Propagation Delay Timing.....	74
Table 54: RMII 10BASE-T Propagation Delay Timing.....	74
Table 55: Absolute Maximum Ratings.....	75
Table 56: Recommended Operating Conditions for BCM5221.....	75
Table 57: Electrical Characteristics.....	76
Table 58: Theta-JA vs. Airflow for the BCM5221KPB(FBGA 64).....	78
Table 59: Theta-JA vs. Airflow for the BCM5221KPT(64 TQFP).....	78



Section 1: Functional Description

OVERVIEW

The BCM5221 is a single-chip Fast Ethernet transceiver. It performs all of the physical layer interface functions for 100BASE-TX full- or half-duplex Ethernet on CAT 5 twisted pair cable and 10BASE-T full- or half-duplex Ethernet on CAT 3, 4 or 5 cable. It may also be configured for 100BASE-FX full- or half-duplex transmission over fiber-optic cabling when paired with an external fiber-optic line driver and receiver.

The chip performs 4B5B, MLT3, NRZI, and Manchester encoding and decoding, clock and data recovery, stream cipher scrambling/descrambling, digital adaptive equalization, line transmission, carrier sense and link integrity monitor, auto-negotiation and Media Independent Interface (MII) management functions. The BCM5221 can be connected to a MAC switch controller through the MII on one side, and connects directly to the network media on the other side (through isolation transformers for unshielded twisted pair (UTP) modes or fiber-optic transmitter/receiver components for FX modes). The BCM5221 is fully compliant with the IEEE 802.3 and 802.3u standards.

ENCODER/DECODER

In 100BASE-TX and 100BASE-FX modes, the BCM5221 transmits and receives a continuous data stream on twisted-pair or fiber-optic cable. When the MII transmit enable is asserted, nibble-wide (4-bit) data from the transmit data pins is encoded into 5-bit code groups and inserted into the transmit data stream. The 4B5B encoding is shown in [Table 1 on page 5](#). The transmit packet is encapsulated by replacing the first 2 nibbles of preamble with a start of stream delimiter (J/K codes) and appending an end of stream delimiter (T/R codes) to the end of the packet. When the MII transmit error input is asserted during a packet, the transmit error code group (H) is sent in place of the corresponding data code group. The transmitter repeatedly sends the idle code group between packets.

In TX mode, the encoded data stream is scrambled by a stream cipher block and then serialized and encoded into MLT3 signal levels. A multi-mode transmit DAC is used to drive the MLT3 data onto the twisted pair cable. In FX mode, the scrambling function is bypassed and the data is NRZI encoded. The multimode transmit DAC drives differential positive ECL (PECL) levels to an external fiber-optic transmitter.

Following baseline wander correction, adaptive equalization, and clock recovery in TX mode, the receive data stream is converted from MLT3 to serial NRZ data. The NRZ data is descrambled by the stream cipher block and then deserialized and aligned into 5-bit code groups.

In FX mode, the receive data stream differential PECL levels are sampled from the fiber-optic receiver. Baseline wander correction, adaptive equalization, and stream cipher descrambling functions are bypassed and NRZI decoding is used instead of MLT3.

The 5-bit code groups are decoded into 4-bit data nibbles, as shown in [Table 1](#). The start of stream delimiter is replaced with preamble nibbles and the end of stream delimiter and idle codes are replaced with all zeros. The decoded data is driven onto the MII receive data pins. When an invalid code group is detected in the data stream, the BCM5221 asserts the MII RXER signal. The chip also asserts RXER for several other error conditions that improperly terminate the data stream. While RXER is asserted, the receive data pins are driven with a 4-bit code indicating the type of error detected. The error codes are listed in [Table 2 on page 6](#).

In 10BASE-T mode, Manchester encoding and decoding is performed on the data stream. The multimode transmit DAC performs pre-equalization for 100 meters of CAT 3 cable.

LINK MONITOR

In 100BASE-TX mode, receive signal energy is detected by monitoring the receive pair for transitions in the signal level. Signal levels are qualified using squelch detect circuits. When no signal or certain invalid signals are detected on the receive pair, the link monitor enters and remains in the link fail state, where only idle codes are transmitted. When a valid signal is detected on the receive pair for a minimum period of time, the link monitor enters the link pass state and the transmit and receive functions are enabled.

In 100BASE-FX mode, the external fiber-optic receiver performs the signal energy detection function and communicates this information directly to the BCM5221 through the differential SD \pm pins.

In 10BASE-T mode, a link-pulse detection circuit constantly monitors the RD \pm pins for the presence of valid link pulses.

CARRIER SENSE

In 100BASE-X modes, carrier sense is asserted asynchronously on the CRS pin as soon as activity is detected in the receive data stream. RXDV is asserted as soon as a valid Start-of-Stream Delimiter (SSD) is detected. Carrier sense and RXDV are deasserted synchronously upon detection of a valid end of stream delimiter or two consecutive idle code groups in the receive data stream. If carrier sense is asserted and a valid SSD is not detected immediately, then RXER is asserted in place of RXDV. A value of 1110 is driven on the receive data pins to indicate false carrier sense.

In 10BASE-T mode, carrier sense is asserted asynchronously on the CRS pin when valid preamble activity is detected on the RD \pm input pins.

In half-duplex DTE mode, the BCM5221 asserts carrier sense while transmit enable is asserted and the link monitor is in the Pass state. In full-duplex mode, CRS is only asserted for receive activity.

COLLISION DETECTION

In half-duplex mode, collision detect is asserted on the COL pin whenever carrier sense is asserted and transmission is in progress.

AUTO-NEGOTIATION

The BCM5221 contains the ability to negotiate its mode of operation over the twisted pair link using the auto-negotiation mechanism defined in the IEEE 802.3u specification. Auto-negotiation can be enabled or disabled by hardware or software control. When the auto-negotiation function is enabled, the BCM5221 automatically chooses its mode of operation by advertising its abilities and comparing them with those received from its link partner.

The BCM5221 can be configured to advertise 100BASE-TX full-duplex and/or half-duplex and 10BASE-T full-and/or half-duplex. The transceiver negotiates with its link partner and chooses the highest level of operation available for its own link. Auto-negotiation is not operational during 100BASE-FX operation.

DIGITAL ADAPTIVE EQUALIZER

The digital adaptive equalizer removes Intersymbol Interference (ISI) created by the transmission channel media. The equalizer accepts sampled unequalized data from the ADC on each channel and produces equalized data. The BCM5221 achieves an optimum signal-to-noise ratio by using a combination of feed forward equalization and decision feedback equalization. This powerful technique achieves a 100BASE-TX BER of less than 1×10^{-12} for transmission up to 100 meters on CAT 5 twisted pair cable, even in harsh noise environments. The digital adaptive equalizers in the BCM5221 achieve performance close to theoretical limits. The all-digital nature of the design makes the performance very tolerant to on-chip noise. The filter coefficients are self-adapting to any quality of cable or cable length. Due to transmit pre-equalization in 10BASE-T mode and complete lack of ISI in 100BASE-FX mode, the adaptive equalizer is bypassed in these two modes of operation.

ADC

The receive channel has a 6-bit, 125-MHz analog-to-digital converter (ADC). The ADC samples the incoming data on the receive channel and produces a 6-bit output. The output of the ADC is fed to the digital adaptive equalizer. Advanced analog circuit techniques achieve low-offset, high-power-supply noise rejection, fast settling time, and low bit error rate.

DIGITAL CLOCK RECOVERY/GENERATOR

The all-digital clock recovery and generator block creates all internal transmit and receive clocks. The transmit clock is locked to the 25-MHz clock input, while the receive clock is locked to the incoming data stream. Clock recovery circuits optimized to MLT3, NRZI, and Manchester encoding schemes are included for use with each of the three different operating modes. The input data stream is sampled by the recovered clock and fed synchronously to the digital adaptive equalizer.

BASELINE WANDER CORRECTION

A 100BASE-TX data stream is not always DC balanced. Because the receive signal must pass through a transformer, the DC offset of the differential receive input can wander. This effect, known as baseline wander, can greatly reduce the noise immunity of the receiver. The BCM5221 automatically compensates for baseline wander by removing the DC offset from the input signal, and thereby significantly reduces the chance of a receive symbol error.

The baseline wander correction circuit is not required, and therefore is bypassed, in 10BASE-T and 100BASE-FX operating modes.

MULTIMODE TRANSMIT DAC

The multimode transmit digital-to-analog converter (DAC) transmits MLT3-coded symbols in 100BASE-TX mode, NRZI-coded symbols in 100BASE-FX mode, and Manchester-coded symbols in 10BASE-T mode. It allows programmable edge-rate control in TX mode, which decreases unwanted high frequency signal components, thus reducing EMI. High-frequency pre-emphasis is performed in 10BASE-T mode; no filtering is performed in 100BASE-FX mode. The transmit DAC utilizes a current drive output, which is well balanced and produces very low noise transmit signals. PECL voltage levels are produced with resistive terminations in 100BASE-FX mode.

STREAM CIPHER

In 100BASE-TX mode, the transmit data stream is scrambled to reduce radiated emissions on the twisted-pair cable. The data is scrambled by exclusive ORing the NRZ signal with the output of an 11-bit-wide linear feedback shift register (LFSR), which produces a 2047-bit non-repeating sequence. The scrambler reduces peak emissions by randomly spreading the signal energy over the transmit frequency range and eliminating peaks at certain frequencies.

The receiver descrambles the incoming data stream by exclusive ORing it with the same sequence generated at the transmitter. The descrambler detects the state of the transmit LFSR by looking for a sequence representing consecutive idle codes. The descrambler locks to the scrambler state after detecting a sufficient number of consecutive idle code-groups. The receiver does not attempt to decode the data stream unless the descrambler is locked. When locked, the descrambler continuously monitors the data stream to make sure that it has not lost synchronization. The receive data stream is expected to contain inter-packet idle periods. If the descrambler does not detect enough idle codes within 724 μ s, it becomes unlocked, and the receive decoder is disabled. The descrambler is always forced into the unlocked state when a link failure condition is detected.

A special mode called High Speed Token Ring can be enabled. It increases the scrambler timeout from 724 μ s to 5816 μ s, thus allowing frames as large as the Token Ring maximum length to be received without error.

Stream cipher scrambling/descrambling is not used in 100BASE-FX and 10BASE-T modes.

FAR-END FAULT

Auto-negotiation provides a remote fault capability for detection of asymmetric link failures. Since auto-negotiation is not available for 100BASE-FX, the BCM5221 implements the IEEE 802.3 standard Far-End Fault mechanism for the indication and detection of remote error conditions. When the Far-End Fault mechanism is enabled, a transceiver transmits the Far-End Fault Indication whenever a receive channel failure is detected (signal detect is deasserted). The transceiver also continuously monitors the receive channel when a valid signal is present (signal detect asserted). When its link partner is indicating a remote error, the transceiver forces its link monitor into the link fail state and sets the remote fault bit in the MII status register.

The Far-End Fault mechanism is enabled by default in 100BASE-FX mode and disabled in 100BASE-TX and 10BASE-T modes, and can be controlled by software after reset.

RMII INTERFACE

In addition to MII interface, the BCM5221 also provides a low pin count (Reduced) Media Independent Interface (RMII) developed by the RMII Consortium. A copy of the specification can be found on the Consortium web site at: <http://www.rmii-consort.com>. This interface provides a low-cost alternative to the IEEE 802.3u[2] MII interface. It is capable of supporting 10 and 100 Mbit data rates with a single clock, using independent 2-bit-wide transmit and receive paths.

MII MANAGEMENT

The BCM5221 contains a complete set of MII management registers accessible by using the management clock line (MDC) and the bidirectional serial data line (MDIO). Many transceivers can be bussed together on a single MDIO/MDC wire pair by giving each a unique PHY address, defined by configuring the five external PHY address input pins.

Every time an MII read or write operation is executed, the BCM5221 compares the operation's PHY address with its own PHY address definition. The operation is executed only when the addresses match.

For further details, see [Section 5: "Register Summary" on page 20](#).

Table 1: 4B5B Encoding

NAME	4B CODE	5B CODE	MEANING
0	0000	11110	Data 0
1	0001	01001	Data 1
2	0010	10100	Data 2
3	0011	10101	Data 3
4	0100	01010	Data 4
5	0101	01011	Data 5
6	0110	01110	Data 6
7	0111	01111	Data 7
8	1000	10010	Data 8
9	1001	10011	Data 9
A	1010	10110	Data A
B	1011	10111	Data B
C	1100	11010	Data C
D	1101	11011	Data D
E	1110	11100	Data E
F	1111	11101	Data F
I	0000*	11111	Idle
J	0101*	11000	Start-of-Stream Delimiter, Part 1
K	0101*	10001	Start-of-Stream Delimiter, Part 2
T	0000*	01101	End-of-Stream Delimiter, Part 1
R	0000*	00111	End-of-Stream Delimiter, Part 2
H	1000	00100	Transmit Error (used to force signalling errors)
V	0111	00000	Invalid Code
V	0111	00001	Invalid Code
V	0111	00010	Invalid Code
V	0111	00011	Invalid Code
V	0111	00101	Invalid Code
V	0111	00110	Invalid Code
V	0111	01000	Invalid Code
V	0111	011000	Invalid Code
V	0111	10000	Invalid Code
V	0111	11001	Invalid Code

* Treated as invalid code (mapped to 0111) when received in data field.



Table 2: Receive Error Encoding

ERROR TYPE	RXD[3:0]
Stream cipher error—descrambler lost lock	0010
Link failure	0011
Premature end of stream	0110
Invalid code	0111
Transmit error	1000
False carrier sense	1110

Section 2: Hardware Signal Definitions

Table 3 provides the pin descriptions for the BCM5221.

Table 3: Pin Descriptions

5221KPB	5221KPT	PIN LABEL	TYPE	DESCRIPTION
MEDIA CONNECTIONS				
H4 G4	26 25	RD+ RD-	I	Receive Pair. Differential data from the media is received on the RD± signal pair.
H5 G5	31 30	TD+ TD-	O	Transmit Pair. Differential data is transmitted to the media on the TD± signal pair.
CLOCK				
D1 C1	6 5	XTALI XTALO	I O	Crystal Input, Output for MII Mode Only. If these pins are used, then REF_CLK must be left open. A 25-MHz, parallel-resonant crystal can be connected between these pins. Accuracy of the crystal is +/- 50 ppm. Connect an appropriate value capacitor from each pin to GND. Whenever REF_CLK pin is used, ground XTALI pin and leave XTALO pin unconnected.
B1	4	REF_CLK	I _{PD}	IIII/RMII Mode 25/50-MHz Reference Clock Input. Whenever REF_CLK pin is used, ground XTALI pin and leave XTALO pin unconnected. This pin must be driven with a continuous 25-MHz or 50-MHz clock for MII or RMII mode, respectively. Accuracy is +/- 50 ppm, with a duty cycle between 35% and 65% inclusive. This pin must be left unconnected when using pins XTALI and XTALO.
MII/RMII INTERFACE				
B6	53	TXC	O _{3S}	Transmit Clock. 25-MHz output in 100BASE-X mode and 2.5 MHz in 10BASE-T MII mode. 10-MHz output in 10BASE-T serial mode. This clock is a continuously driven output, generated from the XTALI input.
B4 B5 A4 A5	60 59 58 57	TXD3 TXD2 TXD1 TXD0	I _{PD}	MII Transmit Data Input. Nibble-wide transmit data stream is input on these pins synchronous with TXC. TXD[3] is the most significant bit. Only TXD0 is used in 10BASE-T serial mode. RMII Transmit Data Input. Dibit data, TXD1 and TXD0, is input on these pins for transmission by the PHY. The data is synchronous with REF_CLK. TXD1 is the most significant bit. Values other than 00 on TXD1 and TXD0 while TXEN is deasserted are ignored by the PHY.
A6	56	TXEN	I _{PD}	MII Transmit Enable. Active high. Indicates that the data nibble on TXD[3:0] is valid. RMII Transmit Enable. Active high. Indicates that the MAC is presenting dibit data, TXD1 and TXD0, for transmission.
A7	52	TXER	I _{PD}	MII/RMII Transmit Error. An active high input is asserted when a transmit error condition is requested by the MAC.
B7	50	RXC	O _{3S}	MII Receive Clock. 25-MHz output in 100BASE-X MII mode and 2.5-MHz output in 10BASE-T mode. 10-MHz output in 10BASE-T serial mode. This clock is recovered from the incoming data on the cable inputs. RXC is a continuously running output clock resynchronized at the start of each incoming packet. This synchronization may result in an elongated period during one cycle while RXDV is low.
[MSB:LSB]; # = active-low signal, I = input, O = output, I/O = bidirectional, I _{PU} = input w/ internal pull-up, O _{OD} = open-drain output, O _{3S} = three-state output, B = Bias, PWR = power supply, GND = ground				

Table 3: Pin Descriptions (Cont.)

5221KPB	5221KPT	PIN LABEL	TYPE	DESCRIPTION
E8 D8 C8 B8	43 44 47 48	RXD3 RXD2 RXD1 RXD0	O _{3S}	MII Receive Data Outputs. Nibble-wide receive data stream is driven out on these pins synchronous with RXC. RXD[3] is the most significant bit. Only RXD0 is used in 10BASE-T serial mode. RMI Receive Data Outputs. Dibit receive data, RXD1 and RXD0, stream is driven out on these pins synchronous with REF_CLK. RXD1 is the most significant bit.
C6	49	RXDV	O _{3S}	MII Receive Data Valid. Active high. Indicates that a receive frame is in progress, and that the data stream present on the RXD output pins is valid.
A8	51	RXER	O _{3S}	MII Receive Error Detected. Active high. Indicates that an error is occurring during a receive frame. RMI Receive Error Detected. RXER is asserted for one or more REF_CLK periods to indicate that an error was detected somewhere in the frame presently being transferred from the PHY. RXER transitions synchronously with respect to REF_CLK.
A3	62	CRS/ CRS_DV	O _{3S}	MII Carrier Sense. Active high. Indicates traffic on link. In 10BASE-X modes, CRS is asserted when a non-idle condition is detected in the receive data stream and deasserted when idle or a valid end of stream delimiter is detected. In 10BASE-T mode, CRS is asserted when a valid preamble is detected and deasserted when end-of-file or an idle condition is detected. CRS is also asserted during transmission of packets except in full-duplex modes. CRS is an asynchronous output signal. RMI Carrier Sense/Receive Data Valid. CRS_DV is asserted by the PHY when the medium is not idle. The dibit data, RXD1 and RXD0, is considered valid once CRS_DV is asserted. During a false carrier event, CRS_DV remains asserted for the duration of carrier activity. CRS_DV is not synchronized with respect to REF_CLK.
B3	61	COL	O _{3S}	Collision Detect. In half-duplex modes, active high output indicates that a collision has occurred. In full-duplex mode, COL remains low. COL is an asynchronous output signal.
E6	41	MDIO	I/O _{PU}	Management Data I/O. This serial input/output bit is used to read from and write to the MII registers. The data value on the MDIO pin is valid and latched on the rising edge of MDC.
D7	42	MDC	I _{PD}	Management Data Clock. The MDC clock input must be provided to allow MII management functions. Clock frequencies up to 12.5 MHz are supported.
MODE				
D2	9	RESET#	I _{PU}	Reset. Active Low. Resets the BCM5221. Also used to enable Power Off and Low Power modes.

[MSB:LSB]; # = active-low signal, I = input, O = output, I/O = bidirectional, I_{PU} = input w/ internal pull-up, O_{OD} = open-drain output, O_{3S} = three-state output, B = Bias, PWR = power supply, GND = ground



Table 3: Pin Descriptions (Cont.)

5221KPB	5221KPT	PIN LABEL	TYPE	DESCRIPTION
E3	14	PHYAD4		PHY Address Selects PHYAD[4:0]. These inputs set the MII management PHY address. These pins are sampled only during power-on reset. During normal operation these pins become outputs.
E2	13	PHYAD3/PAUSE		PAUSE. Status of the link partner's PAUSE bit, bit 10d of MII Link Partner Ability register 05d.
D3	12	PHYAD2/ACT_LED#	I/O _{PD}	Activity LED. Active low. The activity LED is driven low for approximately 80 ms each time there is receive or transmit activity while in the link pass state.
D5	11	PHYAD1/COL_LED#		Collision Detect LED. Active low. This is a stretched COL signal (pin 61) that is suitable for LED display.
C4	10	PHYAD0/FDX_LED#		Full Duplex LED. The Full Duplex LED is driven low when operating in full-duplex mode and driven high in half-duplex mode.
F8	39	FDX	I _{PD}	Full-Duplex Mode. When auto-negotiation is disabled, the FDX pin is logically ORed with register 00, bit 8 to select full-duplex (1) or half-duplex (0) operation.
F6	37	F100 TCK	I _{PU}	Force 100BASE-X Control. When 100BASE-FX mode is not selected, the F100 function is enabled. When F100 is high and ANEN is low, the transceiver is forced to 100BASE-TX operation. When F100 is low and ANEN is low, the transceiver is forced to 10BASE-T operation. When ANEN is high, F100 has no effect on operation. Test Clock. This pin becomes TCK if JTAG_EN pin is high. Clock input used to synchronize JTAG TAP control and data transfers.
F7	38	ANEN TRST#	I _{PU}	Auto-Negotiation Enable. When 100BASE-FX is not selected, the ANEN function is enabled. ANEN is active high. When pulled high, auto-negotiation begins immediately after reset. When low, auto-negotiation is disabled by default. Test Reset. This pin becomes TRST# if JTAG_EN pin is high. Asynchronous active low reset input to the JTAG TAP Controller. Must be set low to ensure the TAP Controller initializes to the test-logic-reset state.
G2	21	SD+		
G1	19	SD-	I _{PD}	100BASE-FX Signal Detect. 100BASE-FX mode is selected if SD+/- pins are presented with a valid PECL differential signal. Leaving this pin unconnected or connecting them to ground causes the BCM5221 to operate in TX mode. When 100BASE-FX is selected, SD+ and SD- indicate signal quality status on the fiber optic link. When the signal quality is good, the SD+ pin will be high relative to the SD-pin.
E4	15	TESTEN	I _{PD}	Test Mode Enable. Active high. Can float or be grounded for normal operation.
F3	18	MII_EN	I _{PU}	MII Enable. Active high. If high, the BCM5221 uses MII signals to communicate with the MAC. Otherwise the BCM5221 uses RMII signals to communicate with the MAC.
F1	16	LOW_PWR	I _{PD}	Low Power Mode Enable. Active high input places the BCM5221 into Low Power operation with the chip deactivated except for the energy detect block and the crystal oscillator. When asserted with RESET# pulled low, the entire chip is deactivated (Power Off mode).
F2	17	ENERGY_DET	O _{3S}	Energy Detection. Active high output indicates the presence of a signal on RD+/-receive analog wire pair. Operational in all modes of operation except IDDQ.

[MSB:LSB]; # = active-low signal, I = input, O = output, I/O = bidirectional, I_{PU} = input w/ internal pull-up, O_{OD} = open-drain output, O_{3S} = three-state output, B = Bias, PWR = power supply, GND = ground

Table 3: Pin Descriptions (Cont.)

5221KPB	5221KPT	PIN LABEL	TYPE	DESCRIPTION
BIAS				
H3	23	RDAC	B	DAC Bias Resistor. Adjusts the current level of the transmit DAC. A resistor of 1.27 kΩ ±1% must be connected between the RDAC pin and GND.
LEDS				
H8	35	LNKLED# MEDIA_CONV# TDI	I/O _{PU}	Link Integrity LED. The Link Integrity LED indicates the link status of the PHY. LNKLED# is driven low when the link to the PHY is good. MEDIA_CONV#. Active low. This pin is sampled during power-on reset. For normal operation leave this pin unconnected. If this pin and MII_EN pin is low during power-on reset, two BCM5221 can be connected back to back for FX to TX media conversion application. Test Data Input. This pin becomes TDI if JTAG_EN is high. Serial data input to the JTAG TAP controller. This pin is sampled on the rising edge of TCK.
G8	36	SPDLED# ADV_PAUSE# TMS	I/O _{PU}	100BASE-X LED. The 100 Base-X LED is driven low when operating in 100BASE-X modes and high when operating in 10BASE-T modes. ADV_PAUSE#. Active low. During power-on reset, this pin is sampled and causes the default value of MII auto-negotiation Advertisement register, 4, bit 10d to be set accordingly. Test Mode Select. This pin becomes TMS if JTAG_EN is high. Single control input to the JTAG TAP controller is used to traverse the test-logic state machine. Sampled on the rising edge of TCK.
G7	34	XMTLED# INTR# FDXLED#	O _{OD}	Transmit Activity LED. Active low output. The transmit activity LED is driven low for approximately 80 ms each time there is transmit activity while in the link pass state. When the interrupt mode is enabled, pin becomes INTR#. When FDXLED mode is enabled, pin becomes FDXLED#.
H7	33	RCVLED# ACTLED# MDIX_DIS TDO	I/O _{PU}	Receive Activity LED. Active low output. The receive activity LED is driven low for approximately 80 ms each time there is receive activity while in the link pass state. In either interrupt or FDXLED mode, pin becomes ACTLED#, indicating both receive and transmit activity. HP Auto-MDIX Disable. Active high. During power-on reset if this pin is high the BCM5221 disables MDI cable cross-over detection. Test Data Output. This pin becomes TDO if JTAG_EN is high. Serial data output from the JTAG TAP controller. Updated on the falling edge of TCK.
JTAG				
A2	64	JTAG_EN	I _{PD}	JTAG Enable. Active high. When high causes the BCM5221 to enter JTAG test mode. For normal operation leave this pin unconnected.
POWER				
A1	3	REGDVDD	PWR	Digital Voltage Regulator Input. Connect this pin to digital 3.3V supply.
H1	20	REGAVDD	PWR	Analog Voltage Regulator Input. Connect this pin to Analog 3.3V supply.
[MSB:LSB]; # = active-low signal, I = input, O = output, I/O = bidirectional, I _{PU} = input w/ internal pull-up, O _{OD} = open-drain output, O _{3S} = three-state output, B = Bias, PWR = power supply, GND = ground				

Table 3: Pin Descriptions (Cont.)

5221KPB	5221KPT	PIN LABEL	TYPE	DESCRIPTION
C3, C5	2, 55	DVDD	PWR	Digital Regulator output (2.5V). Connect these pins to decoupling capacitors as shown in Figure 18 on page 77.
F4, F5	27, 28	AVDD	PWR	Analog Regulator output VDD (2.5V). Connect these pins to decoupling capacitors as shown in Figure 18 on page 77.
B2, E7	1, 46	OVDD	PWR	3.3V Digital Periphery (Output Buffer) VDD supply.
C7, E5	40, 45	OGND	GND	Digital Periphery (OVDD) Ground.
D4, D6,	54, 63	DGND	GND	Digital Ground.
G6, H6	29, 32	AGND	GND	Analog Ground.
E1	7	XTALGND	GND	Crystal Ground.
H2	22	BIASVDD	PWR	BIAS VDD. Connect this pin to AVDD.
G3	24	BIASGND	GND	Bias Ground. Connect this pin to AGND.
C2	8	OVDD/NC	PWR	This pin is for factory test only. For normal operation, leave this pin unconnected or connect to OVDD supply

[MSB:LSB]; # = active-low signal, I = input, O = output, I/O = bidirectional, I_{PU} = input w/ internal pull-up, O_{OD} = open-drain output, O_{3S} = three-state output, B = Bias, PWR = power supply, GND = ground



Section 3: Pinout Diagram

Figure 1 provides the pinout diagram for the BCM5221KPB package.

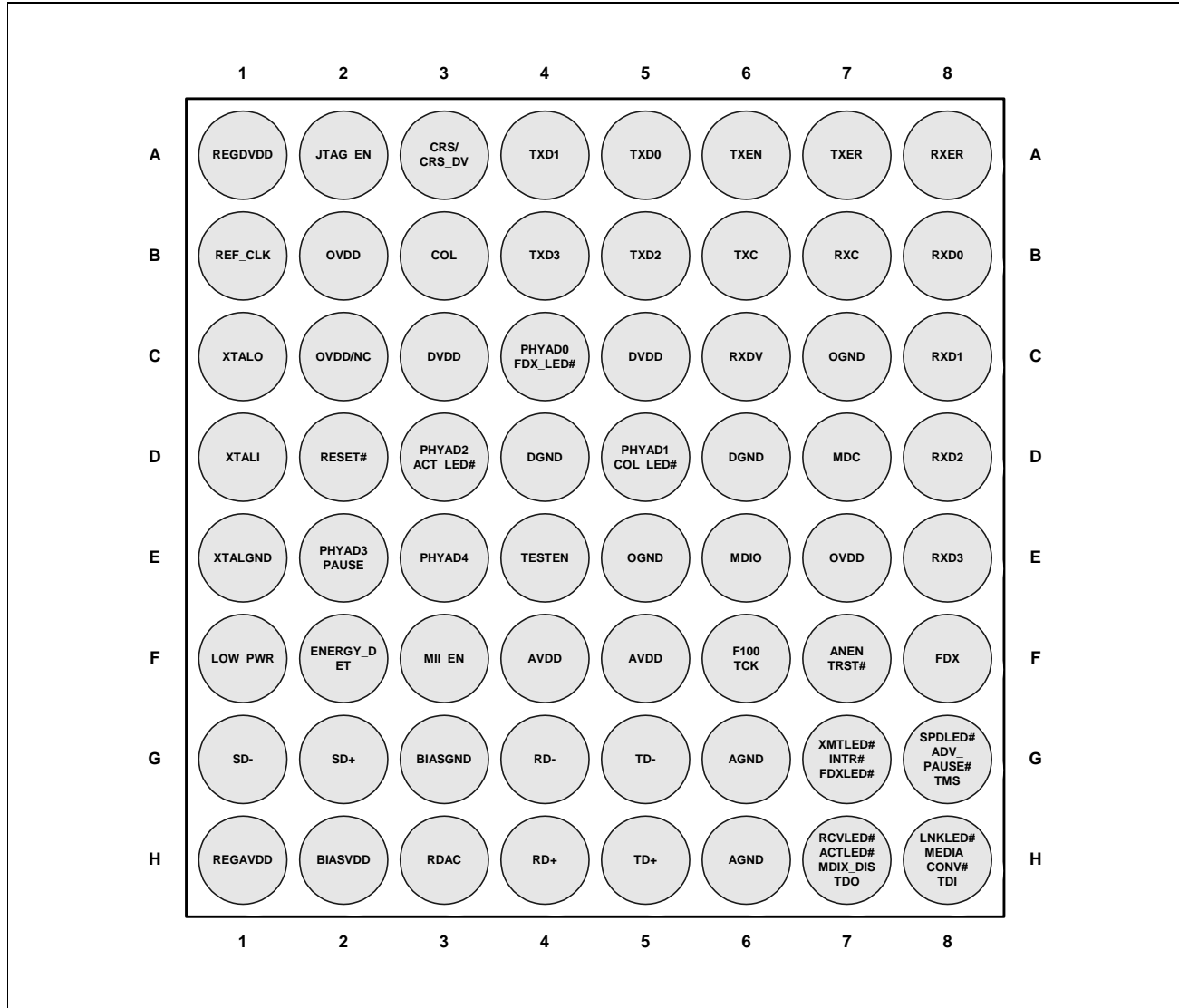

Figure 1: BCM5221KPB Ballout Diagram



Figure 2 provides the pin diagram for the BCM5221KPT.

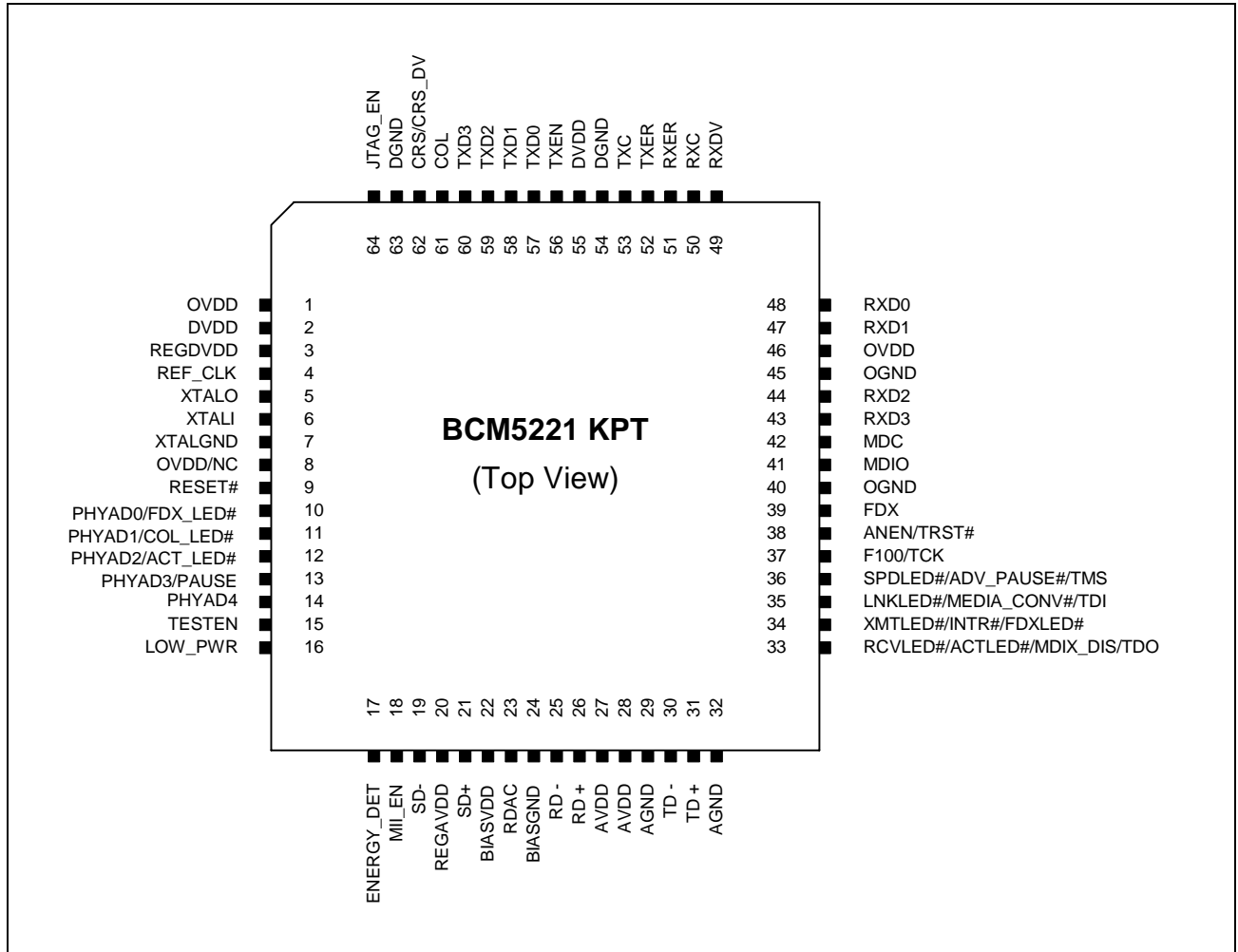

Figure 2: BCM5221KPT Pin Diagram

Section 4: Operational Description

RESET

There are two ways to reset the BCM5221. A hardware reset pin is provided that resets all internal nodes in the chip to a known state. RESET# pin must be held low when powering the BCM5221 to get the chip into normal mode. If the BCM5221 is not provided a power on reset, it is possible for the chip to power-up in a low power mode. To exit this low power mode, RESET# pin must be held low for at least 20 μ s. Hardware reset should always be applied to the BCM5221 after power-up.

The BCM5221 also has a software reset capability. To perform software reset, a 1 must be written to bit 15 of the MII Control register. This bit is self-clearing, meaning that a second write operation is not necessary to end the reset. There is no effect if a 0 is written to the MII Control register reset bit.

The BCM5221 clock input can be driven two ways: internal crystal oscillator or external oscillator. To take advantage of the internal oscillator, attach a 25-MHz crystal between the XTALI and XTALO pins. Connect 27 pF capacitors from each pin to ground. Alternatively, a 50% duty cycle 25-MHz clock can be directly applied to the XTALI pin. In this case, the XTALO output must be left unconnected. No capacitors are used.

ISOLATE MODE

When the BCM5221 is put into isolate mode, all MII inputs (TXD[3:0], TXEN, and TXER) are ignored, and all MII outputs (TXC, COL, CRS, RXC, RXDV, RXER, and RXD[3:0]) are set to high impedance. MII management pins (MDC, MDIO), TD \pm and RD \pm pins operate normally. Writing a 1 to bit 10 of the MII Control register puts the port into isolate mode. Writing a 0 to the same bit removes it from isolate mode. Upon resetting the chip through hardware or software, the isolate mode is off.

SUPER ISOLATE MODE

When the chip is in super isolate mode, in addition to Isolate mode actions, the chip also sets TD \pm pins to high impedance. Writing a 1 to bit 3 of the MII register 1Eh puts the port into super isolate mode. Writing a 0 to the same bit removes it from super isolate mode. Upon resetting the chip through hardware or software, the isolate mode is off.

LOOPBACK MODE

Loopback mode allows in-circuit testing of the BCM5221 chip. All packets sent in through the TXD pins are looped-back internally to the RXD pins, and are not sent out to the cable. The loopback mode is enabled by writing a 1 to bit 14 of the MII Control register. To resume normal operation, bit 14 of the MII Control register must be 0.

Incoming packets on the cable are ignored in loopback mode. Because of this, the COL pin is normally not activated during loopback mode. To test that the COL pin is actually working, the BCM5221 can be placed into collision test mode. This mode is enabled by writing a 1 to bit 7 of the MII Control register. Asserting TXEN causes the COL output to go high, and deasserting TXEN causes the COL output to go low.

FULL-DUPLEX MODE

The BCM5221 supports full-duplex operation. While in full-duplex mode, a transceiver can simultaneously transmit and receive packets on the cable. The COL signal is never activated when in full-duplex mode. The CRS output is asserted only during receive packets, not transmit packets.

By default, the BCM5221 powers up in half-duplex mode. When auto-negotiation is disabled, full-duplex operation can be enabled either by FDX pin control or by an MII register bit (Register 0, bit 8).

When auto-negotiation is enabled in DTE mode, full-duplex capability is advertised by default, but can be overridden by a write to the auto-negotiation Advertisement register (04h).

One of the LED outputs can be modified to signal full-duplex versus half-duplex operation. This capability is enabled by setting MII register 1Ah, bit 15. In this mode, XMTLED# becomes FDXLED#, where a 1 output indicates half-duplex and a 0 output indicates full-duplex. This value is the inverse of MII register 18h, bit 0. When the FDXLED mode is activated, the RCVLED# becomes ACTLED#.

100BASE-FX MODE

For 100BASE-FX mode, the BCM5221 transceiver interfaces with an external 100BASE-FX fiber-optic driver and receiver instead of the magnetics module used with twisted-pair cable. The differential transmit and receive data pairs operate at PECL voltage levels instead of those required for twisted-pair transmission. The data stream is encoded using two-level NRZI instead of three-level MLT3. Since scrambling is not used in 100BASE-FX operation, the stream cipher function is bypassed.

The external fiber-optic receiver detects signal status and passes it into the BCM5221 through the SD± pins. The SD± pins select the 100BASE-FX mode.

10BASE-T MODE

The same magnetics module used in 100BASE-TX mode can be used to interface to the twisted-pair cable when operating in 10BASE-T mode. The data is two-level Manchester encoded instead of three-level MLT3, and no scrambling/descrambling or 4B5B coding is performed. Data and clock rates are decreased by a factor of 10, with the MII interface signals operating at 2.5 MHz.

10BASE-T SERIAL MODE

The BCM5221 supports 10BASE-T serial mode, also known as the 7-wire interface. In this mode, 10BASE-T transmit and receive packets appear at the MII in serial fashion, at a rate of 10 MHz. Receive packet data is output on RXD (0) synchronously with RXC. Transmit packet data must be input on TXD (0) synchronously with TXC. Both clocks toggle at 10 MHz.

The 10BASE-T serial mode is enabled by writing a 1 to bit 1 of the Auxiliary Multiple-PHY register (1Eh). This mode is not available in 100BASE-X modes. The following table shows the MII pins used in this mode and their direction of operation.

Table 4: 10BASE-T Serial Mode (7-Wire) Signals

5221 KPT	PIN LABEL	TYPE	DESCRIPTION
57	TXD (0)	I	Serial Transmit Data
53	TXC	O	Transmit Data Clock (10 MHz)
56	TXEN	I	Transmit Enable
48	RXD (0)	O	Serial Receive Data
50	RXC	O	Receive Data Clock (10 MHz)
62	CRS	O	Carrier Sense
61	COL/RXEN	O	Collision Detect

SPECIAL LED MODES

Traffic Meter Mode.

The blink rate of XMTLED# and RCVLED# is decreased dramatically to better show the volume of traffic. Lower traffic levels make the corresponding LED appear dimmer than higher traffic levels. This mode is activated by writing a 1 to bit 6 of the Aux Mode 2 register (1Bh).

Force LEDs On.

The SPDLED#, LNKLED#, XMTLED#, RCVLED#, COL_LED#, ACT_LED#, and FDX_LED# outputs can be forced on (0 value) by writing a 01 to bit 5 and 4 of shadow register 1Ah.

Disable LEDs.

The SPDLED#, LNKLED#, XMTLED#, RCVLED#, COL_LED#, ACT_LED#, and FDX_LED# outputs can be forced off (1 value) by writing a 10 to bit 5 and 4 of shadow register 1Ah

INTERRUPT MODE

The BCM5221 can be programmed to provide an interrupt output. Three conditions can cause an interrupt to be generated: changes in the duplex mode, changes in the speed of operation or changes in the link status. The interrupt feature is disabled by default. When the interrupt capability is enabled by setting MII register 1Ah, bit 14, the XMTLED# pin becomes the INTR# pin and the RCVLED# pin becomes an activity pin named ACTLED#. The INTR# pin is open-drain and can be wire-ORed with INTR# pins of other chips on a board. The status of each interrupt source is reflected in register 1Ah, bits 1, 2 and 3. If any type of interrupt occurs, the Interrupt Status bit, register 1Ah, bit 0, is set.

The Interrupt register (1Ah) also contains several bits to control different facets of the interrupt function. If the interrupt enable bit is set to 0, no status bits are set and no interrupts are generated. If the interrupt enable bit is set to 1, the following conditions apply:

- If mask status bits (bits 9,10,11) are set to 0 and the interrupt mask (bit 8) is set to 0, status bits and interrupts are available.
- If mask status bits (bits 9,10,11) are set to 0 and the interrupt mask (bit 8) is set to 1, status bits are set but no interrupts generated.
- If any mask status bit is set to 1 and the interrupt mask is set to 0, that status bit is not set and no interrupt of that type is generated.
- If any mask status bit is set to 1 and the interrupt mask is set to 1, that status bit is not set and no interrupt of any kind is generated.

ENERGY DETECTION

An on-chip energy detection circuit can determine when a link partner is connected to the end of the transmission media. The circuit monitors the receive inputs for any type of energy, including 10BASE-T, 100BASE-TX or 100BASE-FX packets, and 10BASE-T or auto-negotiation link pulses. When energy is detected on the receive inputs for longer than 1.3 ms, the ENERGYDET output is asserted. If all traces of energy disappear for longer than 1.3s, it is assumed that the link partner has disconnected, and the ENERGYDET output is deasserted. The energy detection circuit is operational in both full power and some of the low power modes.

POWER SAVING MODES

Several power saving modes are implemented in the BCM5221, which target PCMCIA and CardBus applications. [Table 5 on page 18](#) shows low power modes available in the BCM5221. Low power modes can be achieved either by hardware pin or MII register programming. The table shows both hardware pin and software bits that determine the low power modes and whether the BCM5221 keeps the clocks and the energy detect circuitry active. The BCM5221 requires a hard reset for a minimum of 20 μ s to return to normal mode from a low power mode if the clocks are not running. Allow at least 2 ms before resuming normal operation with the BCM5221 after the device is set to run in normal mode from a low power mode. It is necessary to choose an appropriate low power mode if energy detection function or HP Auto-MDIX support is required while the BCM5221 is in low power mode.

Table 5: Low Power Modes

LOW_PWR	RESET#	FORCE IDDQ	LOW_PWR MODE	ENABLE CLOCK	CLOCKS	ENERGY DETECT	HP AUTO_MDIX
X	0	X	X	X	OFF	OFF	X
0	1	0	0	X	RUN	ON	X
X	X	1	X	X	OFF	OFF	X
1	1	0	0	0	OFF	ON	NO
1	1	0	0	1	RUN	ON	X
0	1	0	1	0	OFF	ON	NO
0	1	0	1	1	RUN	ON	X

LOW_PWR: Pin-16 (BCM5221KPT), Pin-F1 (BCM5221KPB)
RESET#: Pin-9 (BCM5221KPT), Pin-D2 (BCM5221KPB)
FORCE IDDQ: Bit-0 of Shadow register 1Ah
LOW_PWR MODE: Bit-1 of Shadow register 1Ah
ENABLE CLOCK: Bit-2 of Shadow register 1Ah
 X = 1/0 or Don't Care

AUTO POWER DOWN MODE

In addition to various low power modes shown in [Table 5](#), the BCM5221 also supports a special low power mode called Auto Power Down Mode. Auto Power Down mode is enabled by setting bit 5 of Shadow register 1Bh. When in this mode, the BCM5221 automatically enters the low power mode if the energy from the Link partner is lost. Similarly, the next time energy is detected, the chip resumes full power mode. When the BCM5221 is in this low power mode, it wakes up after 2.5/5.0s (approximately), as determined by bit 4 of Shadow register 1Bh, and send link pulse while monitoring energy from the Link partner. If energy is detected, the BCM5221 enters full power mode and establishes link with the Link partner. Otherwise, the wake-up mode continues for a duration of 40-600 ms (approximately) as determined by bits [3:0] of Shadow register 1Bh before going to low power mode. See the Shadow register, [Table 8 on page 24](#), for a details of various bits.



HP AUTO-MDIX

During Auto-Negotiation and in various operating modes, one end of the link must be configured as an MDI (Media Independent Interface) crossover so that each transceiver's transmitter is connected to the other's receiver. The BCM5221 contains the ability to perform HP Auto-MDIX crossover, thus eliminating the need for crossover cable or cross-wired (MDIX) ports.

During Auto-Negotiation and in various operating modes, the BCM5221 normally transmits on TD \pm and receives on RD \pm . When connected via a straight-through cable to another device that does not have HP Auto-MDIX feature, the BCM5221 automatically switches its transmitter to RD \pm and its receiver to TD \pm in order to communicate with that device. If the link partner also has HP Auto-MDIX feature, then a random algorithm determines which end performs the crossover function.

The HP Auto-MDIX feature is implemented in accordance with the IEEE 802.3ab specification. The HP Auto-MDIX crossover feature is a function of Auto-Negotiation. Therefore if the BCM5221 is configured not to perform Auto-Negotiation, the feature will not work, and a specific cable will be required to ensure that each transceiver's transmitter is connected to the other's receiver.

The HP Auto-MDIX feature is enabled in hardware by pulling MDIX_DIS pin low during power on reset. If enabled by hardware, this feature can be disabled by setting bit 11 of MII register 1Ch to a 0.

Section 5: Register Summary

MEDIA INDEPENDENT INTERFACE (MII) MANAGEMENT INTERFACE: REGISTER PROGRAMMING

The BCM5221 fully complies with the IEEE 802.3u Media Independent Interface (MII) specification. The MII management interface registers are serially written to and read from using the MDIO and MDC pins. A single clock waveform must be provided to the BCM5221 at a rate of 0–25MHz through the MDC pin. The serial data is communicated on the MDIO pin. Every MDIO bit must have the same period as the MDC clock. The MDIO bits are latched on the rising edge of the MDC clock.

See [Table 6](#) for the fields in every MII instruction's read or write packet frame.

Table 6: MII Management Frame Format

OPERATION	PRE	ST	OP	PHYAD	REGAD	TA	DATA	IDLE	DIRECTION
READ	1 ... 1	01	10	AAAAA	RRRRR	ZZ Z0	Z ... Z D ... D	Z Z	Driven to BCM5221 Driven by BCM5221
WRITE	1 ... 1	01	01	AAAAA	RRRRR	10	D ... D	Z	Driven to BCM5221

Preamble (PRE).

32 consecutive 1 bits must be sent through the MDIO pin to the BCM5221 to signal the beginning of an MII instruction. Fewer than 32 1 bits causes the remainder of the instruction to be ignored, unless the Preamble Suppression mode is enabled (register 01, bit 6).

Start of Frame (ST).

A 01 pattern indicates that the start of the instruction follows.

Operation Code (OP).

A read instruction is indicated by 10, while a write instruction is indicated by 01.

PHY Address (PHYAD).

A 5-bit PHY address follows next, with the MSB transmitted first. The PHY address allows a single MDIO bus to access multiple transceivers. The BCM5221 supports the full 32-PHY address space.

Register Address (REGAD).

A 5-bit register Address follows, with the MSB transmitted first. The register map of the BCM5221, containing register addresses and bit definitions, are provided on the following pages.

Turnaround (TA).

The next two bit times are used to avoid contention on the MDIO pin when a read operation is performed. For a write operation, 10 must be sent to the chip during these two bit times. For a read operation, the MDIO pin must be placed into high-impedance during these two bit times. The chip drives the MDIO pin to 0 during the second bit time.



Data.

The last 16 bits of the frame are the actual data bits. For a write operation, these bits are sent to the BCM5221. For a read operation, these bits are driven by the BCM5221. In either case, the MSB is transmitted first.

When writing to the BCM5221, the data field bits must be stable 10 ns before the rising-edge of MDC, and must be held valid for 10 ns after the rising edge of MDC. When reading from the BCM5221, the data field bits are valid after the rising edge of MDC until the next rising edge of MDC.

Idle.

A high-impedance state of the MDIO line. All drivers are disabled and the PHY's pull-up resistor pulls the line high. At least one or more clocked idle states are required between frames. Following are two examples of MII write and read instructions.

To put a chip with PHY address 00001 into loopback mode, the following MII write instruction must be issued:

```
1111 1111 1111 1111 1111 1111 1111 1111 0101 00001 00000 10 0100 0000 0000 0000 1...
```

To determine whether a PHY is in the link pass state, the following MII read instruction must be issued:

```
1111 1111 1111 1111 1111 1111 1111 1111 0110 00001 00001 ZZ ZZZZ ZZZZ ZZZZ ZZZZ 1...
```

For the MII read operation, the BCM5221 drives the MDIO line during the TA and Data fields (the last 17 bit times). A final 65th clock pulse must be sent to close the transaction and cause a write operation.

MII REGISTER MAP SUMMARY

Table 7 contains the MII register summary for the BCM5221. The register addresses are specified in hex form, and the name of register bits have been abbreviated. When writing to any register, preserve existing values of the reserved bits by completing a "Read/Modify Write." Ignore reserved bits when reading registers. Never write to an undefined register. The reset values of the registers are shown in the INIT column. Some of these values could be different depending on how the device is configured and also depending on the device revision value.

Table 7: MII Register Map Summary

ADDR	NAME	15	14	13	12	11	10	9	8	7	6	5	4	3	2	1	0	INIT	
00h	CONTROL	Soft Reset	Loop back	Force100	AutoNeg Enable	Power Down	Isolate	Restart AutoNeg	Full Duplex	Collision Test	Reserved							0	3000h
01h	STATUS	T4 Capable	TX FDX Capable	TX Capable	BT FDX Capable	10BT Capable		Reserved			MF pream suppress	AutoNeg comp	Remote Fault	AutoNeg Capable	Link Status	Jabber Detect	Ext'd Reg Capable	7809h	
02h	PHYID HIGH	0	0	0	0	0	0	0	0	0	1	0	0	0	0	0	0	0040h	
03h	PHYID LOW	0	1	1	0	0	0	0	1	1	Model#	Revision #						0	61E0h
04h	AUTONEG ADVERTISE	Next Page	Reserved	Remote Fault	Reserved Tech	Reserved Tech	Pause	Adv T4	Adv TX FDX	Adv TX	Adv BT FDX	Adv BT	0	Advertised Selector Field [4:0]		0	1	01E1h	
05h	LINK PARTNER ABILITY	LP Next Page	LP Acknowledge	LP Rem Fault	Reserved Tech	Reserved Tech	LP Pause	LP T4	LP TX FDX	LP TX	LP BT FDX	LP BT	Link Partner Selector Field [4:0]					0000h	
06h	AUTONEG EXPANSION						Reserved											0004h	
07h	NEXT PAGE	Next Page	Reserved	Message Page	Acknowledge2	Acknowledge2	Toggle	Message/Unformatted Code Field											2001h
08h	LP NEXT PAGE	Next Page	Reserved	Message Page	Acknowledge2	Acknowledge2	Toggle	Message/Unformatted Code Field											0000h
10h	100BASE-X AUX CONTROL	Reserved	Reserved	Trans Disable	Reserved	Reserved	Bypass 4B5B Enc/Dec	Bypass Scram/Descram	Bypass NRZI Enc/Dec	Bypass Rcv Sym Align	BASEline Wander Disable	FEF Enable	Reserved	Extended RMI Out of Band	Reserved	Reserved	0000h		
11h	100BASE-X AUX STATUS		Reserved	Reserved	RMI Over/Under Run	Reserved	FXMode	Locked	Current 100link Status	Current Remote Fault	Reserved	False Carrier Detected	Bad ESD Detected	RCV Error Detected	XMTError Detected	LockError Detected	MLT3 Error Detected	0000h	
12h	100BASE-X RCV ERROR COUNTER						Receive Error Counter [15:0]											0000h	
13h	100BASE-X FALSE CARRIER COUNTER						RMI Over-run/Under-run Counter [7:0]											False Carrier Sense Counter [7:0]	0000h

Table 7: MII Register Map Summary (Cont.)

ADDR	NAME	15	14	13	12	11	10	9	8	7	6	5	4	3	2	1	0	INIT
14h	100BASE-X DISCONNECT COUNTER	RMII Fastrxd	RMII Slowrxd	Reserved														0200h
15h	RESERVED	Reserved																0300h
16h	RESERVED	Reserved																0000h
17h	PTEST	Reserved																0000h
18h	AUXILIARY CONTROL/STATUS	Jabber Disable	Force Link	Reserved														003xh
19h	AUXILIARY STATUS SUMMARY	AutoNeg Complete	AutoNeg CompleteAck	AutoNeg Detect	AutoNeg Ability Detect	AutoNeg Pause	AutoNeg HCD	SPD Mask	FDX Mask	10BT Dribble Correct	HP Auto-MDIX Disable	MDIX Manual Swap	MDIX Status	Reserved	Reserved	Reserved	Reserved	0000h
1Ah	INTERRUPT	FDX LED Enable	INTR Enable	Reserved														9F0xh
1Bh	AUXILIARY MODE2	Reserved																008Ah
1Ch	10BASE-T AUX. ERROR & GENERAL STATUS	Reserved																002xh
1Dh	AUXILIARY MODE	Reserved																x000h
1Eh	AUXILIARY MULTI-PHY	HCD TX FDX	HC T4	HCD TX	HCD 10BT FDX	HCD 10BT	Reserved	Reserved	Restart AutoNeg	AutoNeg Complete	Reserved	ACK Detect	Ability Detect	Super Isolate	Reserved	10BT Serial Mode	RXER Code Mode	0000h
1Fh	BROADCOM TEST	Reserved																000Bh

Table 8: Mill Shadow Register Map Summary

ADDR	NAME	15	14	13	12	11	10	9	8	7	6	5	4	3	2	1	0	INIT	
18h	RESERVED	Reserved																	003Ah
1Ah	AUXILIARY MODE 4	Reserved																	3000h
1Bh	AUXILIARY STATUS 2	MLT3 Detect	Cable Length 100x [2:0]	ADC Peak Amplitude [5:0]		Reserved		LED Force [1:0]		Reserved	APD Sleep Timer	APD Enable	APD Wake-up Timer [3:0]	Enable Clocks During Low Pwr Mode	Force Low Pwr Mode	Force IDIQ Mode	0001h		
1Ch	AUXILIARY STATUS 3	Noise [7:0] (Root Mean Square Error)		FLP Detect	NLP Detect	Link Break Timer Expire	LinkFail Timer Expire	FIFO Consumption[3:0]		Reserved									0000h
1Dh	AUXILIARY MODE 3	Reserved																	0C04h
1Eh	AUXILIARY STATUS4	Packet Length Counter [15:0]																	0000h

MII CONTROL REGISTER

The MII control register bit descriptions are shown in [Table 9](#).

Table 9: MII Control Register (Address 00000b, 0d, 00h)

BIT	NAME	R/W	DESCRIPTION	DEFAULT
15	Reset	R/W (SC)	1 = PHY reset 0 = Normal operation	0
14	Loopback	R/W	1 = Loopback mode 0 = Normal operation	0
13	Forced Speed Selection	R/W	1 = 100 Mbps 0 = 10 Mbps	1
12	Auto-Negotiation Enable	R/W	1 = Auto-negotiation enable 0 = Auto-negotiation disable	1
11	Power Down	RO	0 = Normal operation	0
10	Isolate	R/W	1 = Electrically isolate PHY from MII 0 = Normal operation	0
9	Restart Auto-Negotiation	R/W (SC)	1 = Restart Auto-negotiation process 0 = Normal operation	0
8	Duplex Mode	R/W	1 = Full-duplex 0 = Half-duplex	0
7	Collision Test Enable	R/W	1 = Enable the collision test mode 0 = Disable the collision test mode	0
6:0	Reserved ^a	—	—	0
Note: R/W = Read/Write, RO = Read only, SC = Self Clear, LL = latched low, LH = latched high (LL and LH are cleared after read operation)				

a. When writing to this register, preserve existing values of reserved bits by completing a “Read/Modify Write.”

Reset.

To reset the BCM5221 by software control, a 1 must be written to bit 15 of the Control register using an MII write operation. The bit clears itself after the reset process is complete, and need not be cleared using a second MII write. Writes to other Control register bits has no effect until the reset process is completed, which requires approximately 1 μ s. Writing a 0 to this bit has no effect. Since this bit is self-clearing, within a few cycles after a write operation, it returns a 0 when read.

Loopback.

The BCM5221 may be placed into loopback mode by writing a 1 to bit 14 of the Control register. Clear the loopback mode by writing a 0 to bit 14 of the control register, or by resetting the chip. When this bit is read, it returns a 1 when the chip is in loopback mode, otherwise it returns a 0.

Forced Speed Selection.

If auto-negotiation is enabled (both auto-negotiation pin and bit are enabled) or disabled by hardware control (auto-negotiation pin is pulled-low), this bit has no effect on the speed selection. However, if auto-negotiation is disabled by software control, the operating speed of the BCM5221 can be forced by writing the appropriate value to bit 13 of the Control register. Writing a 1 to this bit forces 100BASE-X operation, while writing a 0 forces 10BASE-T operation. When this bit is

read, it returns the value of the software-controlled forced speed selection only. To read the overall state of forced speed selection, including both hardware and software control, use bit 2 of the Auxiliary Control register (18h).

Auto-Negotiation Enable.

Auto-negotiation can be disabled by one of two methods: hardware or software control. If the ANEN input pin is driven to a logic 0, auto-negotiation is disabled by hardware control. If bit 12 of the Control register is written with a value of 0, auto-negotiation is disabled by software control. When auto-negotiation is disabled in this manner, writing a 1 to the same bit of the Control register or resetting the chip re-enables auto-negotiation. Writing to this bit has no effect when auto-negotiation has been disabled by hardware control. When read, this bit returns the value most recently written to this location, or 1 if it has not been written since the last chip reset.

Power Down

The power modes of the BCM5221 are not accessible by this MII register bit. Use LOWPWR pin control instead.

Isolate.

The PHY can be isolated from its Media Independent Interface by writing a 1 to bit 10 of the Control register. All MII outputs are tri-stated and all MII inputs are ignored. Because the MII management interface is still active, the isolate mode can be cleared by writing a 0 to bit 10 of the control register, or by resetting the chip. When this bit is read, it returns a 1 when the chip is in isolate mode; otherwise it returns a 0.

Restart Auto-Negotiation.

Bit 9 of the Control register is a self-clearing bit that allows the auto-negotiation process to be restarted, regardless of the current status of the auto-negotiation state machine. For this bit to have an effect, auto-negotiation must be enabled. Writing a 1 to this bit restarts the auto-negotiation, while writing a 0 to this bit has no effect. Because the bit is self-clearing after only a few cycles, it always returns a 0 when read. The operation of this bit is identical to bit 8 of the Auxiliary Multiple PHY register (1Eh).

Duplex Mode.

By default, the BCM5221 powers up in half-duplex mode. The chip can be forced into full-duplex mode by writing a 1 to bit 8 of the Control register while auto-negotiation is disabled. Half-duplex mode can be resumed by writing a 0 to bit 8 of the Control register, or by resetting the chip.

Collision Test.

Test the COL pin by activating the collision test mode. While in this mode, asserting TXEN causes the COL output to go high within 512 bit times. Deasserting TXEN causes the COL output to go low within 4 bit times. Writing a 1 to bit 7 of the Control register enables the collision test mode. Writing a 0 to this bit or resetting the chip disables the collision test mode. When this bit is read, it returns a 1 when the collision test mode has been enabled; otherwise it returns a 0. This bit should only be set while in loopback test mode.

Reserved Bits.

All reserved MII register bits must be written as 0 at all times. Ignore the BCM5221 output when these bits are read.



MII STATUS REGISTER

The MII status register bit descriptions are shown in [Table 10](#).

Table 10: MII Status Register (Address 00001B, 01d, 01h)

BIT	NAME	R/W	DESCRIPTION	DEFAULT
15	100BASE-T4 Capability	RO	0 = Not 100BASE-T4 capable	0
14	100BASE-TX FDX Capability	RO	1 = 100BASE-TX full-duplex capable	1
13	100BASE-TX Capability	RO	1 = 100BASE-TX half-duplex capable	1
12	10BASE-T FDX Capability	RO	1 = 10BASE-T full-duplex capable	1
11	10BASE-T Capability	RO	1 = 10BASE-T half-duplex capable	1
10:7	Reserved ^a	–	–	0
6	MF Preamble Suppression	R/W	1 = Preamble may be suppressed 0 = Preamble always required	0
5	Auto-Negotiation Complete	RO	1 = Auto-negotiation process completed 0 = Auto-negotiation process not completed	0
4	Remote Fault	RO	1 = Far-end fault condition detected 0 = No far-end fault condition detected	0
3	Auto-Negotiation Capability	RO	1 = Auto-negotiation capable 0 = Not Auto-negotiation capable	1
2	Link Status	RO LL	1 = Link is up (link pass state) 0 = Link is down (link fail state)	0
1	Jabber Detect	RO LL	1 = Jabber condition detected 0 = No jabber condition detected	0
0	Extended Capability	RO	1 = Extended register capable	1

Note: R/W = Read/Write, RO = Read only, SC = Self Clear, LL = latched low, LH = latched high (LL and LH are cleared after read operation)

a. When writing to this register, preserve existing values of reserved bits by completing a “Read/Modify Write.”

100BASE-T4 Capability.

The BCM5221 is not capable of 100BASE-T4 operation, and returns a 0 when bit 15 of the status register is read.

100BASE-X Full-Duplex Capability.

The BCM5221 is capable of 100BASE-X full-duplex operation, and returns a 1 when bit 14 of the Status register is read.

100BASE-X Half-Duplex Capability.

The BCM5221 is capable of 100BASE-X half-duplex operation, and returns a 1 when bit 13 of the Status register is read.

10BASE-T Full-Duplex Capability.

The BCM5221 is capable of 10BASE-T full-duplex operation, and returns a 1 when bit 12 of the Status register is read.

10BASE-T Half-Duplex Capability.

The BCM5221 is capable of 10BASE-T half-duplex operation, and returns a 1 when bit 11 of the Status register is read.



Reserved Bits.

Ignore the BCM5221 output when these bits are read.

Preamble Suppression.

This bit is the only writable bit in the Status register. Setting this bit to a 1 allows subsequent MII management frames to be accepted with or without the standard preamble pattern. When preamble suppression is enabled, only 2 preamble bits are required between successive management commands, instead of the normal 32.

Auto-Negotiation Complete.

Returns a 1 if auto-negotiation process has been completed and the contents of registers 4, 5, and 6 are valid.

Remote Fault.

The PHY returns a 1 on bit 4 of the status register when its link partner has signalled a far-end fault condition. When a far-end fault occurs, the bit is latched at 1 and remains so until the register is read and the remote fault condition has been cleared.

Auto-Negotiation Capability.

The BCM5221 is capable of performing IEEE auto-negotiation, and returns a 1 when bit 4 of the Status register is read, regardless of whether the auto-negotiation function has been disabled.

Link Status.

The BCM5221 returns a 1 on bit 2 of the Status register when the link state machine is in link pass, indicating that a valid link has been established. Otherwise, it returns 0. When a link failure occurs after the link pass state has been entered, the link status bit is etched at 0 and remains so until the bit is read. After the bit is read, it becomes 1 when the link pass state is entered again.

Jabber Detect.

10BASE-T operation only. The BCM5221 returns a 1 on bit 1 of the Status register if a jabber condition has been detected. After the bit is read once, or if the chip is reset, it reverts to 0.

Extended Capability.

The BCM5221 supports extended capability registers, and returns a 1 when bit 0 of the Status register is read. Several extended registers have been implemented in the BCM5221, and their bit functions are defined later in this section.

PHY IDENTIFIER REGISTERS

The physical identifier registers bit descriptions are shown in [Table 11](#).

Table 11: PHY Identifier Registers (Addresses 00010 and 00011b, 02 and 03b, 02 and 03h)

<i>BIT</i>	<i>NAME</i>	<i>R/W</i>	<i>DESCRIPTION</i>	<i>VALUE</i>
15:0	MII Address 02h	RO	PHYID HIGH	0040h
15:0	MII Address 03h	RO	PHYID LOW	61E0h

Broadcom Corporation has been issued an Organizationally Unique Identifier (OUI) by the IEEE. It is a 24-bit number, 00-10-18, expressed as hex values. That number, along with the Broadcom Model Number for the BCM5221 part, 1Eh, and Broadcom Revision number, 0h for the A0 is placed into two MII registers. The translation from OUI, Model Number and Revision Number to PHY Identifier register occurs as follows:

- PHYID HIGH [15:0] = OUI[21:6]
- PHY LOW [15:0] = OUI[5:0] + MODEL[5:0] + REV[3:0]

The 2 most significant bits of the OUI are not represented (OUI[23:22]).

[Table 11](#) shows the result of concatenating these values to form MII Identifier registers PHYID HIGH and PHYID LOW.

AUTO-NEGOTIATION ADVERTISEMENT REGISTER

Table 12: Auto-Negotiation Advertisement Register (Address 04d, 04h)

BIT	NAME	R/W	DESCRIPTION	DEFAULT
15	Next Page	R/W	1 = Next page ability is enabled 0 = Next page ability is disabled	0
14	Reserved ^a	–	–	
13	Remote Fault	R/W	1 = Transmit remote fault	0
12:11	Reserved Technologies	RO	Ignore when read	00
10	Pause	R/W	1 = Pause operation for full-duplex	0
9	Advertise 100BASE-T4	R/W	1 = Advertise T4 capability 0 = Do not advertise T4 capability	0
8	Advertise 100BASE-X FDX	R/W	1 = Advertise 100BASE-X full-duplex 0 = Do not advertise 100BASE-X full-duplex	1
7	Advertise 100BASE-X	R/W	1 = Advertise 100BASE-X	1
6	Advertise 10BASE-T FDX	R/W	1 = Advertise 10BASE-T full-duplex 0 = Do not advertise 10BASE-T full-duplex	1
5	Advertise 10BASE-T	R/W	1 = Advertise 10BASE-T	1
4:0	Advertise Selector Field	R/W	Indicates 802.3	00001

Note: R/W = Read/Write, RO = Read only, SC = Self Clear, LL = Latched Low, LH = Latched High, LL & LH Clear after read operation. Use default values of reserved bit(s) when writing to reserved bit(s).

a. When writing to this register, preserve existing values of reserved bits by completing a “Read/Modify Write.”

Next Page. The BCM5221 supports the next page function.

Reserved Bits.

Ignore output when read.

Remote Fault.

Writing a 1 to bit 13 of the Advertisement register causes a remote fault indicator to be sent to the link partner during auto-negotiation. Writing a 0 to this bit or resetting the chip clears the remote fault transmission bit. This bit returns the value last written to it, or else 0 if no write has been completed since the last chip reset.

Reserved Technologies Bits.

Ignore output when read.

Pause

Pause operation for full-duplex links. The use of this bit is independent of the negotiated data rate, medium, or link technology. The setting of this bit indicates the availability of additional DTE capability when full-duplex operation is in use. This bit is used by one MAC to communicate pause capability to its link partner and has no effect on PHY operation.



Advertisement Bits

Use bits 9:5 of the Advertisement register to customize the ability information transmitted to the link partner. The default value for each bit reflects the abilities of the BCM5221. By writing a 1 to any of the bits, the corresponding ability can be transmitted to the link partner. Writing a 0 to any bit causes the corresponding ability to be suppressed from transmission. Resetting the chip restores the default bit values. Reading the register returns the values last written to the corresponding bits, or else the default values if no write has been completed since the last chip reset.

Selector Field

Bits 4:0 of the Advertisement register contain the value 00001, indicating that the chip belongs to the 802.3 class of PHY transceivers.



AUTO-NEGOTIATION LINK PARTNER (LP) ABILITY REGISTER

Table 13: Auto-Negotiation Link Partner Ability Register (Address 05d, 05h)

BIT	NAME	R/W	DESCRIPTION	DEFAULT
15	LP Next Page	RO	Link partner next page bit	0
14	LP Acknowledge	RO	Link partner acknowledge bit	0
13	LP Remote Fault	RO	Link partner remote fault indicator	0
12:11	Reserved Technologies	RO	Ignore when read	000
10	LP Advertise Pause	RO	Link partner has pause capability	0
9	LP Advertise 100BASE-T4	RO	Link partner has 100BASE-T4 capability	0
8	LP Advertise 100BASE-X FDX	RO	Link partner has 100BASE-X FDX capability	0
7	LP Advertise 100BASE-X	RO	Link partner has 100BASE-X capability	0
6	LP Advertise 10BASE-T FDX	RO	Link partner has 10BASE-T FDX capability	0
5	LP Advertise 10BASE-T	RO	Link partner has 10BASE-T capability	0
4:0	Link Partner Selector Field	RO	Link partner selector field	00000

Notes: R/W = Read/Write, RO = Read only, SC = Self Clear, LL = Latched Low, LH = Latched High, LL & LH Clear after read operation. Use default values of reserved bit(s) when writing to reserved bit(s).

The values contained in the Auto-Negotiation Link Partner Ability register are only guaranteed to be valid after auto-negotiation has successfully completed, as indicated by bit 5 of the MII Status register.

LP Next Page.

Bit 15 of the Link Partner Ability register returns a value of 1 when the link partner implements the next page function and has next page information that it wants to transmit. The BCM5221 does not implement the next page function, and thus ignores the next page bit, except to copy it to this register.

LP Acknowledge.

Bit 14 of the Link Partner Ability register is used by auto-negotiation to indicate that a device has successfully received its link partner's link code word.

LP Remote Fault.

Bit 13 of the Link Partner Ability register returns a value of 1 when the link partner signals that a remote fault has occurred. The BCM5221 simply copies the value to this register and does not act upon it.

Reserved Bits.

Ignore when read.

LP Advertise Pause.

Indicates that the Link Partner Pause bit is set.

LP Advertise Bits.

Bits 9:5 of the Link Partner Ability register reflect the abilities of the link partner. A 1 on any of these bits indicates that the link partner is capable of performing the corresponding mode of operation. Bits 9:5 are cleared any time auto-negotiation is restarted or the BCM5221 is reset.

LP Selector Field.

Bits 4:0 of the Link Partner Ability register reflect the value of the link partner's selector field. These bits are cleared any time auto-negotiation is restarted or the chip is reset.



AUTO-NEGOTIATION EXPANSION REGISTER

Table 14 shows the Auto-Negotiation Expansion register bit descriptions.

Table 14: Auto-Negotiation Expansion Register (Address 00110b, 6d, 06h)

BIT	NAME	R/W	DESCRIPTION	DEFAULT
15:5	Reserved ^a	-	-	000h
4	Parallel Detection Fault	RO LH	1 = Parallel detection fault 0 = No parallel detection fault	0
3	Link Partner Next Page Able	RO	1 = Link partner has next page capability 0 = Link partner does not have next page	0
2	Next Page Able	RO	1 = BCM5221 does have next page capability	1
1	Page Received	RO	1 = New page has been received 0 = New page has not been received	0
0	Link Partner Auto-Negotiation Able	RO LH	1 = Link partner has auto-negotiation capability 0 = Link partner does not have auto-negotiation	0

Note: R/W = Read/Write, RO = Read only, SC = Self Clear, LL = latched low, LH = latched high (LL and LH are cleared after read operation)

a. When writing to this register, preserve existing values of reserved bits by completing a "Read/Modify Write."

Reserved Bits.

Ignore when read.

Parallel Detection Fault.

Bit 4 of the Auto-Negotiation Expansion register is a read-only bit that gets latched high when a parallel detection fault occurs in the auto-negotiation state machine. For further details, refer to the IEEE standard. The bit is reset to 0 after the register is read, or when the chip is reset.

Link Partner Next Page Able.

Bit 3 of the Auto-Negotiation Expansion register returns a 1 when the link partner has next page capabilities. It has the same value as bit 15 of the Link Partner Ability register.

Next Page Able.

The BCM5221 returns 1 when bit 2 of the Auto-Negotiation Expansion register is read, indicating that it has next page capabilities.

Page Received.

Bit 1 of the Auto-Negotiation Expansion register is latched high when a new link code word is received from the link partner, checked, and acknowledged. It remains high until the register is read, or until the chip is reset.

Link Partner Auto-Negotiation Able.

Bit 0 of the Auto-Negotiation Expansion register returns a 1 when the link partner is known to have auto-negotiation capability. Before any auto-negotiation information is exchanged, or if the link partner does not comply with IEEE auto-negotiation, the bit returns a value of 0.



AUTO-NEGOTIATION NEXT PAGE REGISTER

Table 15: Next Page Transmit Register (Address 07d, 07h)

BIT	NAME	R/W	DESCRIPTION	DEFAULT
15	Next Page	R/W	1 = Additional next page(s) will follow 0 = Last page	0
14	Reserved ^a	-	-	0
13	Message Page	R/W	1 = Message page 0 = Unformatted page	1
12	Acknowledge 2	R/W	1 = Will comply with message 0 = Cannot comply with message	0
11	Toggle	RO	1 = Previous value of the transmitted link code word equalled logic zero 0 = Previous value of the transmitted link code word equalled logic one	0
10:0	Message/Unformatted Code Field	R/W		1

Note: R/W = Read/Write, RO = Read only, SC = Self Clear, LL = Latched Low, LH = Latched High, LL & LH Clear after read operation. Use default values of reserved bit(s) when writing to reserved bit(s).

a. When writing to this register, preserve existing values of reserved bits by completing a "Read/Modify Write."

Next Page.

Indicates whether this is the last next page to be transmitted.

Message Page.

Differentiates a Message Page from an Unformatted Page.

Acknowledge 2.

Indicates that a device has the ability to comply with the message.

Toggle.

Used by the Arbitration function to ensure synchronization with the link partner during next page exchange.

Message Code Field.

An 11-bit-wide field, encoding 2048 possible messages.

Unformatted Code Field.

An 11-bit-wide field, which may contain an arbitrary value.

AUTO-NEGOTIATION LINK PARTNER (LP) NEXT PAGE TRANSMIT REGISTER

Table 16: Next Page Transmit Register (Address 08d, 08h)

BIT	NAME	R/W	DESCRIPTION	DEFAULT
15	Next Page	RO	1 = Additional next page(s) will follow 0 = Last page	0
14	Reserved ^a	-	-	0
13	Message Page	RO	1= Message page 0 = Unformatted page	0
12	Acknowledge 2	RO	1 = Will comply with message 0 = Cannot comply with message	0
11	Toggle	RO	1 = Previous value of the transmitted link code word equalled logic zero 0 = Previous value of the transmitted link code word equalled logic one	0
10:0	Message/Unformatted Code Field	RO		0

Note: R/W = Read/Write, RO = Read only, SC = Self Clear, LL = Latched Low, LH = Latched High, LL & LH Clear after read operation. Use default values of reserved bit(s) when writing to reserved bit(s).

a. When writing to this register, preserve existing values of reserved bits by completing a "Read/Modify Write."

Next Page.

Indicates whether this is the last next page.

Message Page.

Differentiates a Message Page from an Unformatted Page.

Acknowledge 2.

Indicates that link partner has the ability to comply with the message.

Toggle.

Used by the Arbitration function to ensure synchronization with the link partner during next page exchange.

Message Code Field.

An 11-bit-wide field, encoding 2048 possible messages.

Unformatted Code Field.

An 11-bit-wide field, which may contain an arbitrary value.

100BASE-X AUXILIARY CONTROL REGISTER)

Table 17: 100-BASE-X Auxiliary Control Register (Address 16d, 10h)

BIT	NAME	R/W	DESCRIPTION	DEFAULT
15:14	Reserved ^a	-	-	0
13	Transmit Disable	R/ W	1 = Transmitter disabled in PHY 0 = Normal operation	0
12	Reserved ^a	-	-	0
11	Reserved ^a	-	-	0
10	Bypass 4B5B Encoder/ Decoder	R/ W	1 = Transmit and receive 5B codes over RMII pins 0 = Normal RMII interface	0
9	Bypass Scrambler/ Descrambler	R/ W	1 = Scrambler and descrambler disabled 0 = Scrambler and descrambler enabled	0
8	Bypass NRZI Encoder/ Decoder	R/ W	1 = NRZI encoder and decoder is disabled 0 = NRZI encoder and decoder is enabled	0
7	Bypass Receive Symbol Alignment	R/ W	1 = 5B receive symbols not aligned 0 = Receive symbols aligned to 5B boundaries	0
6	Baseline Wander Correction Disable	R/ W	1 = Baseline wander correction disabled 0 = Baseline wander correction enabled	0
5	FEF Enable	R/ W	1 = Far end fault enabled 0 = Far end fault disabled	0
4:3	Reserved ^a	-	-	0
2	Extended FIFO Enable	R/ W	1 = Extended FIFO mode, 0 = Normal FIFO mode	0
1	RMII Out-of-Band Enable	R/ W	1 = Enabled, 0 = Disabled	0
0	Reserved ^a	-	-	0

Note: R/W = Read/Write, RO = Read only, SC = Self Clear, LL = Latched Low, LH = Latched High, LL & LH Clear after read operation. Use default values of reserved bit(s) when writing to reserved bit(s).

a. When writing to this register, preserve existing values of reserved bits by completing a "Read/Modify Write."

Transmit Disable.

The transmitter can be disabled by writing a 1 to bit 13 of MII register 10h. The transmitter output (TD \pm) is forced into a high impedance state.

Bypass 4B5B Encoder/Decoder.

The 4B5B encoder and decoder can be bypassed by writing a 1 to bit 10 of MII register 10h. The transmitter sends 5B codes from the TXER and TXD1, TXD0 pins directly to the scrambler. TXEN must be active and frame encapsulation (insertion of J/K and T/R codes) is not performed. The receiver places descrambled and aligned 5B codes onto the RXER, RXD1 and RXD0 pins. CRS can be asserted when a valid frame is received.



Bypass Scrambler/Descrambler.

The stream cipher function can be disabled by writing a 1 to bit 9 of MII register 10h. The stream cipher function is re-enabled by writing a 0 to this bit.

Bypass NRZI Encoder/Decoder.

The NRZI encoder and decoder can be bypassed by writing a 1 to bit 8 of MII register 10h, causing 3-level NRZ data to be transmitted and received on the cable. Normal operation (3-level NRZI encoding and decoding) can be re-enabled by writing a 0 to this bit.

Bypass Receive Symbol Alignment.

Receive symbol alignment can be bypassed by writing a 1 to bit 7 of MII register 10h. When used in conjunction with the bypass 4B5B encoder/decoder bit, unaligned 5B codes are placed directly on the RXER and RXD1, RXD0 pins.

Baseline Wander Correction Disable.

The baseline wander correction circuit can be disabled by writing a 1 to bit 6 of MII register 10h. The BCM5221 corrects for baseline wander on the receive data signal when this bit is cleared.

FEF Enable.

Controls the far end fault mechanism associated with 100BASE-FX operation. A 1 enables the FEF function and a 0 disables it.

Extended RMII FIFO Enable.

Controls the extended RMII FIFO mechanism.

RMII Out-of-Band Enable.

Controls the RMII out-of band mechanism within the RMII receive logic.

Reserved Bits.

The reserved bits of the 100BASE-X Auxiliary Control register must be written as 0 at all times. Ignore the BCM5221 outputs when these bits are read.

100BASE-X AUXILIARY STATUS REGISTER

Table 18: 100BASE-X Auxiliary Status Register (Address 17d, 11h)

BIT	NAME	R/W	DESCRIPTION	DEFAULT
15:12	Reserved ^a	-	-	0
11	RMII Overrun/Underrun Detected	RO	1 = Error detected 0 = No error	0
10	FX Mode	RO	1 = 100BASE-FX mode 0 = 100BASE-TX or 10BASE-T mode	PIN
9	Locked	RO	1 = Descrambler locked 0 = Descrambler unlocked	0
8	Current 100BASE-X Link Status	RO	1 = Link pass 0 = Link fail	0
7	Remote Fault	RO	1 = Remote fault detected 0 = No remote fault detected	0
6	Reserved ^a	-	-	0
5	False Carrier Detected	RO LH	1 = False carrier detected since last read 0 = No false carrier since last read	0
4	Bad ESD Detected	RO LH	1 = ESD error detected since last read 0 = No ESD error since last read	0
3	Receive Error Detected	RO LH	1 = Receive error detected since last read 0 = No receive error since last read	0
2	Transmit Error Detected	RO LH	1 = Transmit error code received since last read 0 = No transmit error code received since last read	0
1	Lock Error Detected	RO LH	1 = Lock error detected since last read 0 = No lock error since last read	0
0	MLT3 Code Error Detected	RO LH	1 = MLT3 code error detected since last read 0 = No MLT3 code error since last read	0

R/W = Read/Write, RO = Read only, SC = Self Clear, LL = Latched Low, LH = Latched High, LL & LH Clear after read operation. Use default values of reserved bit(s) when writing to reserved bit(s).

a. When writing to this register, preserve existing values of reserved bits by completing a "Read/Modify Write."

RMII Over-run/Under-run Error.

The PHY returns a 1 in bit 11, when the RMII receive FIFO encounters an over-run or under-run condition.

FX Mode.

Returns a value derived from the SD_± input pins. Returns 1 when SD_± are driven with a valid differential signal level. Returns 0 when both SD₊ and SD₋ are simultaneously driven low.

Locked.

The PHY returns a 1 in bit 9 when the descrambler is locked to the incoming data stream. Otherwise it returns a 0.

Current 100BASE-X Link Status.

The PHY returns a 1 in bit 8 when the 100BASE-X link status is good. Otherwise it returns a 0.



Remote Fault.

The PHY returns a 1 while its link partner is signalling a far-end fault condition. Otherwise it returns a 0.

False Carrier Detected.

The PHY returns a 1 in bit 5 of the Extended Status register if a false carrier has been detected since the last time this register was read. Otherwise it returns a 0.

Bad ESD Detected.

The PHY returns a 1 in bit 4 if an end of stream delimiter error has been detected since the last time this register was read. Otherwise it returns a 0.

Receive Error Detected.

The PHY returns a 1 in bit 3 if a packet was received with an invalid code since the last time this register was read. Otherwise it returns a 0.

Transmit Error Detected.

The PHY returns a 1 in bit 2 if a packet was received with a transmit error code since the last time this register was read. Otherwise it returns a 0.

Lock Error Detected.

The PHY returns a 1 in bit 1 if the descrambler has lost lock since the last time this register was read. Otherwise it returns a 0.

MLT3 Code Error Detected.

The PHY returns a 1 in bit 0 if an MLT3 coding error has been detected in the receive data stream since the last time this register was read. Otherwise it returns a 0.

100BASE-X RECEIVE ERROR COUNTER

Table 19: 100BASE-X Receive Error Counter (Address 18d, 12h)

<i>BIT</i>	<i>NAME</i>	<i>R/W</i>	<i>DESCRIPTION</i>	<i>DEFAULT</i>
15:0	Receive Error Counter [15:0]	R/W	Number of non-collision packets with receive errors since last read	0000h

Receive Error Counter [15:0].

This counter increments each time the BCM5221 receives a non-collision packet containing at least one receive error. The counter automatically clears itself when read. When the counter reaches its maximum value, FFh, it stops counting receive errors until cleared.

100BASE-X FALSE CARRIER SENSE COUNTER

Table 20: 100BASE-X False Carrier Sense Counter (Address 19d, 13h)

<i>BIT</i>	<i>NAME</i>	<i>R/W</i>	<i>DESCRIPTION</i>	<i>DEFAULT</i>
15:8	RMII Over-run/Under-run Counter [7:0]	R/W	Number of RMII over-runs/under-runs since last read	00h
7:0	False Carrier Sense Counter [7:0]	R/W	Number of false carrier sense events since last read	00h

RMII Over-run/Under-run Counter [7:0].

The RMII over-run/under-run counter will increment each time the BCM5221 detects an over-run or under-run of the RMII FIFOs. The counter automatically clears itself when read. When the counter reaches its maximum value, FFh, it stops counting over-run/under-run errors until cleared.

False Carrier Sense Counter [7:0].

This counter increments each time the BCM5221 detects a false carrier on the receive input. This counter automatically clears itself when read. When the counter reaches its maximum value, FFh, it stops counting False Carrier Sense Errors until cleared.

100BASE-X DISCONNECT COUNTER

Table 21: 100BASE-X Disconnect Counter (Address 20d, 14h)

<i>BIT</i>	<i>NAME</i>	<i>R/W</i>	<i>DESCRIPTION</i>	<i>DEFAULT</i>
15	RMII Fast RXD	R/O	1 = In extended FIFO mode, detect fast receive data 0 = Normal	0
14	RMII Slow RXD	R/O	0 = Normal 1 = In extended FIFO mode, detect slow receive data	0
13:8	Reserved ^a	-	-	000010
7:0	Reserved ^a	-	-	00h

Note: R/W = Read/Write, RO = Read only, SC = Self Clear, LL = Latched Low, LH = Latched High, LL & LH Clear after read operation. Use default values of reserved bit(s) when writing to reserved bit(s).

a. When writing to this register, preserve existing values of reserved bits by completing a "Read/Modify Write."

RMII Fast RXD.

Extended FIFO operation only. Bit 15 of the Disconnect counter register indicates the FIFO state machine has detected fast receive data relative to the REF_CLK input.

RMII Slow RXD.

Extended FIFO operation only. Bit 14 of the Disconnect counter register indicates the FIFO state machine has detected slow receive data relative to the REF_CLK input.

PTEST REGISTER

The bit description for the PTEST register is shown in Table 22.

Table 22: PTEST Register (Address 10111b, 23d, 17h)

BIT	NAME	R/W	DESCRIPTION	DEFAULT
15:0	Reserved ^a	-	-	0000h

a. When writing to this register, preserve existing values of reserved bits by completing a "Read/Modify Write."

AUXILIARY CONTROL/STATUS REGISTER

The Auxiliary Control/Status register bit descriptions are shown in Table 23.

Table 23: Auxiliary Control/Status Register (Address 24d, 18h)

BIT	NAME	R/W	DESCRIPTION	DEFAULT
15	Jabber Disable	R/W	1 = Jabber function disabled 0 = Jabber function enabled	0
14	Force Link	R/W	1 = Force 10BASE-T link pass 0 = Normal 10BASE-T link operation	0
13:8	Reserved ^a	-	-	000000
7:6	HSQ : LSQ	R/W	These two bits define the squelch mode of the 10BASE-T Carrier Sense mechanism 00 = Normal Squelch 01 = Low Squelch 10 = High Squelch 11 = Not Allowed	00
5:4	Edge Rate [1:0]	R/W	00 = 1 ns 01 = 2 ns 10 = 3 ns 11 = 4 ns	11
3	Auto-Negotiation Indication	RO	1 = Auto-negotiation activated 0 = Speed forced manually	ANEN Pin
2	Force 100/10 Indication	RO	1 = Speed forced to 100BASE-X 0 = Speed forced to 10BASE-T	F100 Pin
1	Speed Indication	RO	1 = 100BASE-X 0 = 10BASE-T	F100 Pin, if ANEN pin is 0
0	Full-Duplex Indication	RO	1 = Full-duplex active 0 = Full-duplex not active	FDX Pin

a. When writing to this register, preserve existing values of reserved bits by completing a "Read/Modify Write."



Jabber Disable

10BASE-T operation only. Bit 15 of the Auxiliary Control register allows the user to disable the jabber detect function, defined in the IEEE standard. This function shuts off the transmitter when a transmission request has exceeded a maximum time limit. By writing a 1 to bit 15 of the Auxiliary Control register, the jabber detect function is disabled. Writing a 0 to this bit or resetting the chip restores normal operation. Reading this bit returns the value of jabber detect disable.

Link Force.

Writing a 1 to bit 14 of the Auxiliary Control register allows the user to disable the Link Integrity state machines, and place the BCM5221 into forced link pass status. Writing a 0 to this bit or resetting the chip restores the Link Integrity functions. Reading this bit returns the value of the force link bit.

HSQ and LSQ.

Extend or decrease the squelch levels for detection of incoming 10BASE-T data packets. The default squelch levels implemented are those defined in the IEEE standard. The high-and low-squelch levels are useful for situations where the IEEE-prescribed levels are inadequate. The squelch levels are used by the CRS/LINK block to filter out noise and recognize only valid packet preambles and link integrity pulses. Extending the squelch levels allows the BCM5221 to operate properly over longer cable lengths. Decreasing the squelch levels can be useful in situations where there is a high level of noise present on the cables. Reading these 2 bits returns the value of the squelch levels.

Edge Rate.

Control bits used to program the transmit DAC output edge rate in 100BASE-TX mode. A larger value on these bits produces slower transitions on the transmit waveform.

Auto-Negotiation Indication.

This read-only bit indicates whether auto-negotiation has been enabled or disabled on the BCM5221. A combination of a 1 in bit 12 of the Control register and a logic 1 on the ANEN input pin is required to enable auto-negotiation. When auto-negotiation is disabled, bit 3 of the Auxiliary Control register (18h) returns a 0. At all other times, it returns a 1.

Force 100/10 Indication.

This read-only bit returns a value of 0 when one of following cases is true:

- The ANEN pin is low AND the F100 pin is low.
- The ANEN pin is high AND bit 12 of the Control register has been written 0 and bit 13 of the Control register has been written 0.

When bit 2 of the Auxiliary Control register (18h) is 0, the speed of the chip is 10BASE-T. In all other cases, either the speed is not forced (auto-negotiation is enabled), or the speed is forced to 100BASE-X.

Speed Indication.

This read-only bit shows the true current operation speed of the BCM5221. A 1 indicates 100BASE-X operation, and a 0 indicates 10BASE-T. While the auto-negotiation exchange is performed, the BCM5221 is always operating at 10BASE-T speed.

Full-Duplex Indication.

This read-only bit returns a 1 when the BCM5221 is in full-duplex mode. In all other modes, it returns a 0.

AUXILIARY STATUS SUMMARY REGISTER

The Auxiliary Status Summary Register contains copies of redundant status bits found elsewhere within the MII register space. Descriptions for each of these individual bits can be found associated with their primary register descriptions. Table 24 indicates the bits found in this register.

Table 24: Auxiliary Status Summary Register (Address 25d, 19h)

BIT	NAME	R/W	DESCRIPTION	DEFAULT
15	Auto-Negotiation Complete	RO	1 = Auto-negotiation process completed	0
14	Auto-Negotiation Complete Acknowledge	RO LH	1 = Auto-negotiation completed acknowledge state	0
13	Auto-Negotiation Acknowledge Detected	RO LH	1 = Auto-negotiation acknowledge detected	0
12	Auto-Negotiation Ability Detect	RO LH	1 = Auto-negotiation for link partner ability	0
11	Auto-Negotiation Pause	RO	BCM5221 and link partner pause operation bit	0
10:8	Auto-Negotiation HCD	RO	000 = No highest common denominator 001 = 10BASE-T 010 = 10BASE-T Full-Duplex 011 = 100BASE-TX 100 = 100BASE-T4 101 = 100BASE-TX Full-Duplex 11x = Undefined	000
7	Auto-Negotiation Parallel Detection Fault	RO LH	1 = Parallel detection fault	0
6	Link Partner Remote Fault	RO	1 = Link partner remote fault	0
5	Link Partner Page Received	RO LH	1 = New page has been received	0
4	Link Partner Auto-Negotiation Able	RO	1 = Link partner is auto-negotiation capable	0
3	Speed Indicator	RO	1 = 100 Mbps 0 = 10 Mbps	
2	Link Status	RO LL	1 = Link is up (link pass state)	0
1	Auto-Negotiation Enabled	RO	1 = Auto-negotiation enabled	ANEN pin
0	Jabber Detect	RO LH	1 = Jabber condition detected	0

Note: R/W = Read/Write, RO = Read only, SC = Self Clear, LL = latched low, LH = latched high (LL and LH are cleared after read operation)

INTERRUPT REGISTER

Table 25: Interrupt Register (Address 26d, 1Ah)

BIT	NAME	R/W	DESCRIPTION	DEFAULT
15	FDX LED Enable	R/W	1 = Enable Full-duplex LED output on G7/34 0 = Enable XMTLED or Interrupt LED if Interrupt is enabled.	0
14	INTR Enable	R/W	Interrupt enable	0
13:12	Reserved	RO	Ignore when read	00
11	FDX Mask	R/W	Full-Duplex interrupt mask	1
10	SPD Mask	R/W	SPEED interrupt mask	1
9	LINK Mask	R/W	LINK interrupt mask	1
8	INTR Mask	R/W	Master interrupt mask	1
7:4	Reserved ^a	-	-	000
3	FDX Change	RO LH	Duplex change interrupt	0
2	SPD Change	RO LH	Speed change interrupt	0
1	LINK Change	RO LH	Link change interrupt	0
0	INTR Status	RO LH	Interrupt status	0

Note: R/W = Read/Write, RO = Read only, SC = Self Clear, LL = Latched Low, LH = Latched High, LL & LH Clear after read operation. Use default values of reserved bit(s) when writing to reserved bit(s).

a. When writing to this register, preserve existing values of reserved bits by completing a "Read/Modify Write."

FDX LED Enable

When this bit is set to a "1", FDX LED pin G7(BGA)/34(PQFP) will output FDX status. Otherwise, when INTR Enable is set to a "1" it will output Interrupt state. When both bits are "0", it will output XMT state.

Interrupt Enable

Setting this bit enables Interrupt Mode.

FDX Mask

When this bit is set, changes in Duplex mode will not generate an interrupt.

SPD Mask

When this bit is set, changes in operating speed will not generate an interrupt.

Link Mask

When this bit is set, changes in Link status will not generate an interrupt.



Interrupt Mask

Master Interrupt Mask. When this bit is set, no interrupts will be generated, regardless of the state of the other MASK bits.

FDX Change

A “1” indicates a change of Duplex status since last register read. Register read clears the bit.

SPD Change

A “1” indicates a change of Speed status since last register read. Register read clears the bit.

Link Change

A “1” indicates a change of Link status since last register read. Register read clears the bit.

Interrupt Status

Represents status of the INTR# pin. A “1” indicates that the interrupt mask is off and that one or more of the change bits are set. Register read clears the bit.

AUXILIARY MODE 2 REGISTER

Table 26: Auxiliary Mode 2 Register (Address 27d, 1Bh)

<i>BIT</i>	<i>NAME</i>	<i>R/W</i>	<i>DESCRIPTION</i>	<i>DEFAULT</i>
15:12	Reserved ^a	-	-	0
11	10BT Dribble Bit Correct	R/W	1 = Enable, 0 = Disable	0
10	Token Ring Mode	R/W	1 = Enable, 0 = Disable	0
9	HSTR FIFO Enable	R/W	1 = Enable, 0 = Disable	0
8	Reserved	RO	Ignore when read	0
7	Block 10BT Echo Mode	R/W	1 = Enable, 0 = Disable	1
6	Traffic Meter LED Mode	R/W	1 = Enable, 0 = Disable	0
5	Activity LED Force On	R/W	1 = ON, 0 = Normal operation	0
4	Reserved ^a	-	-	1
3	Reserved ^a	-	-	1
2	Activity/Link LED Mode	R/W	1 = Enable, 0 = Disable	0
1	Qual Parallel Detect Mode	R/W	1 = Enable, 0 = Disable	1
0	Reserved ^a	-	-	0

Note: R/W = Read/Write, RO = Read only, SC = Self Clear, LL = Latched Low, LH = Latched High, LL & LH Clear after read operation. Use default values of reserved bit(s) when writing to reserved bit(s).

a. When writing to this register, preserve existing values of reserved bits by completing a “Read/Modify Write.”

10BT Dribble Bit Correct. When enabled, the PHY rounds down to the nearest nibble when dribble bits are present on the 10Base-T input stream.

Token Ring Mode.

When enabled, the 100BASE-X unlock timer changes to allow long packets.

HSTR FIFO Mode.

When enabled, the RMII receive FIFO doubles from 7 nibbles to 14 nibbles.

Block 10BT Echo Mode.

When enabled, during 10BASE-T half-duplex transmit operation, the TXEN signal does not echo onto the RXDV pin. The TXEN echoes onto the CRS pin and the CRS deassertion directly follows the TXEN deassertion.

Traffic Meter LED Mode.

When enabled, the Activity LEDs (ACTLED# and FDXLED# if full-duplex LED and interrupt LED modes are not enabled) does not blink based on the internal LED clock (approximately 80 ms on time). Instead, they blink based on the rate of Receive and Transmit activity. Each time a Receive or Transmit operation occurs, the LED turns on for a minimum of 5 ms. During light traffic, the LED blinks at a low rate, while during heavier traffic the LEDs remains on.

Activity LED Force On.

When asserted, the Activity LEDs (ACTLED# and FDXLED# if full-duplex LED and interrupt LED modes are not enabled) is turned on. This bit has a higher priority than the Activity LED force Inactive, bit 4, register 1Dh.

Activity/Link LED Mode.

When enabled, the RCVLED# output goes active upon acquiring link and pulses during Receive or Transmit activity.

Qualified Parallel Detect Mode.

This bit allows the auto-negotiation/parallel detection process to be qualified with information in the Advertisement register.

If this bit is not set, the local BCM5221 device is enabled to Auto-Negotiate, and the far-end device is a 10BASE-T or 100BASE-X non-Auto-Negotiating legacy type, the local device Auto-Negotiate/Parallel detects the far-end device, regardless of the contents of its Advertisement register (04h).

If this bit is set, the local device compares the link speed detected to the contents of its Advertisement register. If the particular link speed is enabled in the Advertisement register, the local device asserts link. If the link speed is disabled in this register, then the local device does not assert link and continues monitoring for a matching capability link speed.

10BASE-T AUXILIARY ERROR & GENERAL STATUS REGISTER

Table 27: 10BASE-T Auxiliary Error & General Status Register (Address 28d, 1Ch)

BIT	NAME	R/W	DESCRIPTION	DEFAULT
15:14	Reserved ^a	-	-	0
13	MDIX Status	RO	0 = MDI is in use 1 = MDIX is in use	0
12	MDIX Manual Swap	RW	0 = MDI or MDIX if MDIX is not disabled 1 = Force MDIX	0
11	HP Auto-MDIX disable	R/W	0 = Enable HP Auto-MDIX 1 = Disable HP Auto-MDIX	MDIX_DIS pin
10	Manchester Code Error	RO	1 = Manchester code error (10BASE-T)	0
9	End Of Frame Error	RO	1 = EOF detection error (10BASE-T)	0
8	Reserved ^a	-	-	0
7:5	Reserved ^a	-	-	001
4	Reserved ^a	-	-	0
3	Auto-Negotiation Indication	RO	1 = Auto-negotiation activated 0 = Speed forced manually	1
2	Force 100/10 Indication	RO	1 = Speed forced to 100BASE-X 0 = Speed forced to 10BASE-T	1
1	Speed Indication	RO	1 = 100BASE-X 0 = 10BASE-T	0
0	Full-duplex Indication	RO	1 = Full-duplex active 0 = Full-duplex not active	0

Note: All Error bits in the Auxiliary Error and General Status register are read-only and are latched high. When certain types of errors occur in the BCM5221, one or more corresponding error bits become "1". They remain so until the register is read, or until a chip reset occurs. All such errors necessarily result in data errors, and are indicated by a high value on the RXER output pin at the time the error occurs.

Note: R/W = Read/Write, RO = Read only, SC = Self Clear, LL = Latched Low, LH = Latched High, LL & LH Clear after read operation. Use default values of reserved bit(s) when writing to reserved bit(s).

a. When writing to this register, preserve existing values of reserved bits by completing a "Read/Modify Write."

MDIX Status.

When read as a 1, this bit indicates that the BCM5221 has its MDI TD_± and RD_± signals swapped either due to manually setting MDIX Swap bit to a 1 or through HP Auto-MDIX function if it is enabled and the BCM5221 has detected a MDI cross-over cable.

MDIX Manual Swap.

When this bit is set to a 1, the BCM5221 forces its MDI TD_± and RD_± signals to be swapped.

HP Auto-MDIX Disable.

When this bit is set to a 1, then the BCM5221 disables the HP Auto-MDIX function.



Manchester Code Error.

Indicates that a Manchester code violation was received. This bit is only valid during 10BASE-T operation.

End of Frame Error.

Indicates that the End Of Frame (EOF) sequence was improperly received, or not received at all. This error bit is only valid during 10BASE-T operation.

Auto-Negotiation Indication.

This read-only bit indicates whether auto-negotiation has been enabled or disabled on the BCM5221. A combination of a 1 in bit 12 of the Control register and a logic 1 on the ANEN input pin is required to enable auto-negotiation. When auto-negotiation is disabled, bit 15 of the Auxiliary Mode register returns a 0. At all other times, it returns a 1.

Force 100/10 Indication.

This read-only bit returns a value of 0 when one of following two cases is true:

- The ANEN pin is low AND the F100 pin is low. (or)
- Bit 12 of the Control register has been written 0 AND bit 13 of the Control register has been written 0.

When bit 2 of the Auxiliary Control register is 0, the speed of the chip is 10BASE-T. In all other cases, either the speed is not forced (auto-negotiation is enabled), or the speed is forced to 100BASE-X.

Speed Indication.

This read-only bit shows the true current operation speed of the BCM5221. A 1 bit indicates 100BASE-X operation, while a 0 indicates 10BASE-T. While the auto-negotiation exchange is performed, the BCM5221 is always operating at 10BASE-T speed.

Full-Duplex Indication.

This read-only bit returns a 1 when the BCM5221 is in full-duplex mode. In all other modes, it returns a 0.

AUXILIARY MODE REGISTER

Table 28 shows the bit descriptions for the Auxiliary Mode register.

Table 28: Auxiliary Mode Register (Address 29d, 1Dh)

BIT	NAME	R/W	DESCRIPTION	DEFAULT
15:5	Reserved ^a	-	-	xxxh
4	Activity LED Disable	R/W	1 = Disable XMT/RCV activity LED outputs 0 = Enable XMT/RCV activity LED outputs	0
3	Link LED Disable	R/W	1 = Disable link LED output 0 = Enable link LED output	0
2	Reserved ^a	-	-	0
1	Block TXEN Mode	R/W	1 = Enable block TXEN mode 0 = Disable block TXEN mode	0
0	Reserved ^a	-	-	0

a. When writing to this register, preserve existing values of reserved bits by completing a "Read/Modify Write."

Activity LED Disable.

When set to 1, disables the XMTLED# and RCVLED# output pins. When 0, XMTLED# and RCVLED# output pins are enabled.

Link LED Disable.

When set to 1, disables the Link LED output pin. When 0, Link LED output is enabled.

Block TXEN Mode.

When this mode is enabled, short IPGs of 1, 2, 3 or 4 TXC cycles results in the insertion of two IDLEs before the beginning of the next packet's JK symbols.



AUXILIARY MULTIPLE PHY REGISTER

Table 29: Auxiliary Multiple PHY Register (Address 30d, 1Eh)

BIT	NAME	R/W	DESCRIPTION	DEFAULT
15	HCD_TX_FDX	RO	1 = Auto-negotiation result is 100BASE-TX full-duplex	0
14	HCD_T4	RO	1 = Auto-negotiation result is 100BASE-T4	0
13	HCD_TX	RO	1 = Auto-negotiation result is 100BASE-TX	0
12	HCD_10BASE-T_FDX	RO	1 = Auto-negotiation result is 10BASE-T full-duplex	0
11	HCD_10BASE-T	RO	1 = Auto-negotiation result is 10BASE-T	0
10:9	Reserved ^a	-	-	00
8	Restart Auto-Negotiation	R/W (SC)	1 = Restart auto-negotiation process 0 = (No effect)	0
7	Auto-Negotiation Complete	RO	1 = Auto-negotiation process completed 0 = Auto-negotiation process not completed	0
6	Acknowledge Complete	RO	1 = Auto-negotiation acknowledge completed	0
5	Acknowledge Detected	RO	1 = Auto-negotiation acknowledge detected	0
4	Ability Detect	RO	1 = Auto-negotiation waiting for LP ability	0
3	Super Isolate	R/W	1 = Super isolate mode 0 = Normal operation	0
2	Reserved ^a	-	-	0
1	10BASE-T Serial Mode	R/W	1 = Enable 10BASE-T serial mode 0 = Disable 10BASE-T serial mode	0
0	Reserved ^a	-	-	0

Note: R/W = Read/Write, RO = Read only, SC = Self Clear, LL = Latched Low, LH = Latched High, LL & LH Clear after read operation. Use default values of reserved bit(s) when writing to reserved bit(s).

a. When writing to this register, preserve existing values of reserved bits by completing a "Read/Modify Write."

HCD Bits.

Bits 15:11 of the Auxiliary Multiple PHY register are 5 read-only bits that report the Highest Common Denominator (HCD) result of the auto-negotiation process. Immediately upon entering the link pass state after each reset or restart auto-negotiation, only 1 of these 5 bits is 1. The link pass state is identified by a 1 in bit 6 or 7 of this register. The HCD bits are reset to 0 every time auto-negotiation is restarted or the BCM5221 is reset. For their intended application, these bits uniquely identify the HCD only after the first link pass after reset or restart of auto-negotiation. On later Link Fault and subsequent re-negotiations, if the ability of the link partner is different, more than 1 of the above bits can be active.

Restart Auto-Negotiation.

This self-clearing bit allows the auto-negotiation process to be restarted, regardless of the current status of the state machine. For this bit to work, auto-negotiation must be enabled. Writing a 1 to this bit restarts auto-negotiation. Since the bit is self-clearing, it always returns a 0 when read. The operation of this bit is identical to bit 9 of the Control register.



Auto-Negotiation Complete.

This read-only bit returns a 1 after the auto-negotiation process has been completed. It remains 1 until the auto-negotiation process is restarted, a Link Fault occurs, or the chip is reset. If auto-negotiation is disabled or the process is still in progress, the bit returns a 0.

Acknowledge Complete.

This read-only bit returns a 1 after the acknowledgment exchange portion of the auto-negotiation process has been completed and the Arbitrator state machine has exited the Complete Acknowledge state. It remains this value until the auto-negotiation process is restarted, a Link Fault occurs, auto-negotiation is disabled, or the BCM5221 is reset.

Acknowledge Detected.

This read-only bit is set to 1 when the arbitrator state machine exits the acknowledged detect state. It remains high until the auto-negotiation process is restarted, or the BCM5221 is reset.

Ability Detect.

This read-only bit returns a 1 when the auto-negotiation state machine is in the Ability Detect state. It enters this state a specified time period after the auto-negotiation process begins, and exits after the first FLP burst or link pulses are detected from the link partner. This bit returns a 0 any time the auto-negotiation state machine is not in the Ability Detect state.

Super Isolate.

Writing a 1 to this bit places the BCM5221 into the Super Isolate mode. Similar to the Isolate mode, all RMII inputs are ignored, and all RMII outputs are tri-stated. Additionally, all link pulses are suppressed. This allows the BCM5221 to coexist with another PHY on the same adapter card, with only one being activated at any time.

10BASE-T Serial Mode.

Writing a 1 to bit 1 of the Auxiliary Mode register enables the 10BASE-T Serial mode. In the normal 10BASE-T mode of operation, as defined by the RMII standard, transmit and receive data packets traverse the TXD1, TXD0 and RXD1, RXD0 busses at a rate of 50 MHz. In the special 10BASE-T Serial mode, data packets traverse to the MAC layer across only TXD0 and RXD0 at a rate of 10 MHz. Serial operation is not available in 100BASE-X mode.

BROADCOM TEST REGISTER

Table 30: Broadcom Test (Address 31d, 1Fh)

<i>BIT</i>	<i>NAME</i>	<i>R/W</i>	<i>DESCRIPTION</i>	<i>DEFAULT</i>
15:8	Reserved ^a	-	-	00h
7	Shadow register enable	R/W	1 = Enable shadow registers 0 = Disable shadow registers	0
6	Reserved ^a	-	-	0
5	Reserved ^a	-	-	0
4:0	Reserved ^a	-	-	0Bh

Notes: *R/W = Read/Write, RO = Read only, SC = Self Clear, LL = Latched Low, LH = Latched High, LL & LH Clear after read operation. Use default values of reserved bit(s) when writing to reserved bit(s).*

a. When writing to this register, preserve existing values of reserved bits by completing a "Read/Modify Write."

Shadow Register Enable.

Writing a 1 to bit 7 of register 1Fh allows R/W access to the shadow registers.

AUXILIARY MODE 4 REGISTER (SHADOW REGISTER)

Table 31: Auxiliary Mode 4 Register (Shadow Register 26d, 1Ah)

BIT	NAME	R/W	DESCRIPTION	DEFAULT
15:6	Reserved ^a	-	-	30h
5:4	Force LED [1:0]	R/W	01 = Force all LED status to on 0 state 10 = Force all LED status to off 1 state	00
3	Reserved ^a	-	-	0
2	Enable Clock During Low Power	R/W	0 = Disables clock during low power modes 1 = Enables clock during low power modes	0
1	Force Low Power Mode	R/W	0 = Normal operation 1 = Forces the 5221 to enter the low power mode	0
0	Force IDDQ Mode	R/W	0 = Normal operation 1 = Causes the BCM5221 to go to IDDQ mode	0

Notes: R/W = Read/Write, RO = Read only, SC = Self Clear, LL = Latched Low, LH = Latched High, LL & LH Clear after read operation. Use default values of reserved bit(s) when writing to reserved bit(s). MII Shadow register bank 1 is accessed by setting MII register 1Fh bit 7 to a 1.

a. When writing to this register, preserve existing values of reserved bits by completing a "Read/Modify Write."

Force LED [1:0]

The SPDLED#, LNKLED#, XMTLED#, RCDLED#, COL_LED#, ACT_LED# and FDX_LED# outputs can be forced to on state (0) by writing a value of 01 to Force LED [1:0]. These LEDs can be forced to off state (1) by writing a value of 10 to Force LED [1:0].

Enable Clock During Low Power

If this bit is set to a 1 then the clocks are running in low mode.

Force IDDQ Mode.

If this bit is set to a 1, then the BCM5221 enters IDDQ mode. When the device is in IDDQ mode, everything is disabled. The BCM5221 requires a hard reset to return to normal mode.

AUXILIARY STATUS 2 REGISTER (SHADOW REGISTER)

Table 32: Auxiliary Status 2 Register (Shadow Register 27d, 1Bh)

<i>BIT</i>	<i>NAME</i>	<i>R/W</i>	<i>DESCRIPTION</i>	<i>DEFAULT</i>
15	MLT3 Detected	R/O	1 = MLT3 Detected	0h
14:12	Cable Length 100X [2:0]	R/O	The BCM5221 shows the cable length in 20 meters increment as shown in the table below	000
11:6	ADC Peak Amplitude [5:0]	R/O	A to D peak amplitude seen	00h
5	APD Enable	R/W	0 = Normal mode 1 = Enable auto power down mode	0
4	APD Sleep Timer	R/W	0 = 2.5 sec sleep before wake-up 1 = 5.0 sec sleep before wake-up	0
3:0	APD Wake-up Timer [3:0]	R/W	Duration of wake-up	0001

Notes: R/W = Read/Write, RO = Read only, SC = Self Clear, LL = Latched Low, LH = Latched High, LL & LH Clear after read operation. Use default values of reserved bit(s) when writing to reserved bit(s). MII Shadow register bank 1 is accessed by setting MII register 1Fh bit 7 to a 1.

MLT3 Detected.

The BCM5221 returns a 1 in this bit whenever MLT3 signaling is detected.

Cable Length 100X [2:0].

The BCM5221 provides the cable length for each port when a 100TX link is established.

Table 33: Cable Length

<i>CABLE LENGTH 100X [2:0]</i>	<i>CABLE LENGTH IN METERS</i>
000	< 20
001	20 to <40
010	40 to <60
011	60 to < 80
100	80 to < 100
101	100 to < 120
110	120 to < 140
111	> 140

ADC Peak Amplitude [5:0].

The BCM5221 returns the AD converter's 6-bit peak amplitude seen during this link.

APD Enable

When in normal mode, if this bit set to a 1, the BCM5221 enters auto power down mode. If this bit is set, the BCM5221 enters low power mode whenever the link is lost. When energy is detected the device enters full power mode. Otherwise, it wakes-up after 2.5s or 5.0s, as determined by the APD Sleep Timer bit. When the BCM5221 wakes up, it sends link pulses and monitors energy. If the link partner's energy is detected then the BCM5221 enters full power mode and establishes a link with the Link partner. If no energy is detected from the link partner, it continues to stay in wake-up mode for a duration determined by the APD Wake-up Timer before going to low power mode.

APD Sleep Timer

This bit determines how long the BCM5221 stays in low power mode before wake-up. If this bit is a 0 then it waits approximately 2.5s before wake-up, else 5s.

APD Wake-up Timer [3:0]

This counter determines how long the BCM5221 stays up in wake-up mode before going to low-power mode. This value is specified in 40-ms increments from 0 to 600 ms. A value of 0 forces the BCM5221 to stay in low-power mode indefinitely. In this case the BCM5221 requires a hard reset to return to normal mode.

AUXILIARY STATUS 3 REGISTER (SHADOW REGISTER)

Table 34: Auxiliary Status 3 Register (Shadow Register 28d, 1Ch)

<i>BIT</i>	<i>NAME</i>	<i>R/W</i>	<i>DESCRIPTION</i>	<i>DEFAULT</i>
15:8	Noise [7:0]	R/O	Current mean square error value, valid only if link is established	00h
7:4	Reserved ^a	-	-	000h
3:0	FIFO Consumption [3:0]	R/O	Currently utilized number of nibbles in the receive FIFO	0000

MII Shadow register bank 1 is accessed by setting MII register 1Fh bit 7 to a 1

a. When writing to this register, preserve existing values of reserved bits by completing a "Read/Modify Write."

Noise [7:0].

The BCM5221 provides the current mean squared error value for noise when a valid link is established.

FIFO Consumption [3:0].

The BCM5221 indicates the number of nibbles of FIFO currently used.



AUXILIARY MODE 3 REGISTER (SHADOW REGISTER)

Table 35: Auxiliary Mode 3 Register (Shadow Register 29d, 1Dh)

BIT	NAME	R/W	DESCRIPTION	DEFAULT
15:4	Reserved ^a	-	-	000h
3:0	FIFO Size Select [3:0]	R/W	Currently selected receive FIFO Size	4h

Note: R/W = Read/Write, RO = Read only, SC = Self Clear, LL = Latched Low, LH = Latched High, LL & LH Clear after read operation. Use default values of reserved bit(s) when writing to reserved bit(s). MII Shadow register bank 1 is accessed by setting MII register 1Fh bit 7 to a 1.

a. When writing to this register, preserve existing values of reserved bits by completing a "Read/Modify Write."

FIFO Size Select [3:0].

The BCM5221 indicates the current selection of receive FIFO size using bit 3 through 0 as shown in [Table 36](#). The size can also be determined by bit "Extended RMII FIFO Enable." on [page 37](#).

Table 36: Current Receive FIFO Size

FIFO SIZE SELECT [3:0]	RECEIVE FIFO SIZE IN USE (# OF BITS)
0001	16
0010	20
0011	24
0100	28
0101	32
0110	36
0111	40
1000	44
1001	48
1010	52
1011	56
1100	60
1101	64

AUXILIARY STATUS 4 REGISTER (SHADOW REGISTER)

Table 37: Auxiliary Status 4 Register (Shadow Register 30d, 1Eh)

<i>BIT</i>	<i>NAME</i>	<i>R/W</i>	<i>DESCRIPTION</i>	<i>DEFAULT</i>
15:0	Packet Length Counter[15:0]	R/O	Number of bytes in the last received packet	0000h

Packet Length Counter [15:0].

The BCM5221 shows the number bytes in the last packet received. This is valid only when a valid link is established.

Section 6: Timing and AC Characteristics

The timing information contained in this section applies to the BCM5221.

All MII Interface pins comply with IEEE 802.3u timing specifications (see Reconciliation Sublayer and Media Independent Interface in IEEE 802.3u timing specifications). All digital output timing specified at $C_L = 30$ pF.

Output rise/fall times measured between 10% and 90% of the output signal swing. Input rise/fall times measured between V_{IL} max. and V_{IH} min. Output signal transitions referenced to the midpoint of the output signal swing. Input signal transitions referenced to the midpoint between V_{IL} max. and V_{IH} min. See [Table 38](#) and [Table 39](#) for the timing parameters. See [Figure 3](#) for an illustration of clock and reset timing.

Table 38: Clock Timing

PARAMETER	SYMBOL	MIN	TYP	MAX	UNIT
XTALI Cycle Time	CK_CYCLE	39.998	40	40.002	ns
XTALI High/Low Time	CK_HI CK_LO	14	20	26	ns
REF_CLK Cycle Time (MII - 25 MHz)			40		ns
REF_CLK High/Low Time (MII - 25 MHz)		13	20	27	ns
REF_CLK Rise/Fall Time (MII - 25 MHz)				4	ns
REF_CLK Cycle Time (RMII - 50 MHz)			20	2	ns
REF_CLK High/Low Time (RMII - 50 MHz)		7	10	13	ns
REF_CLK Rise/Fall Time (RMII - 50 MHz)				2	ns

Table 39: Reset Timing

PARAMETER	SYMBOL	MIN	TYP	MAX	UNIT
Reset Pulse Length with stable XTALI Input (see note)	RESET_LEN	400			ns
Activity after end of Hardware Reset	RESET_WAIT	100			μ s
RESET# Rise/Fall Time	RESET_EDGE			10	ns
Note: During power-on, RESET# pin must be held low to get the BCM5221 to power-up in normal mode.					

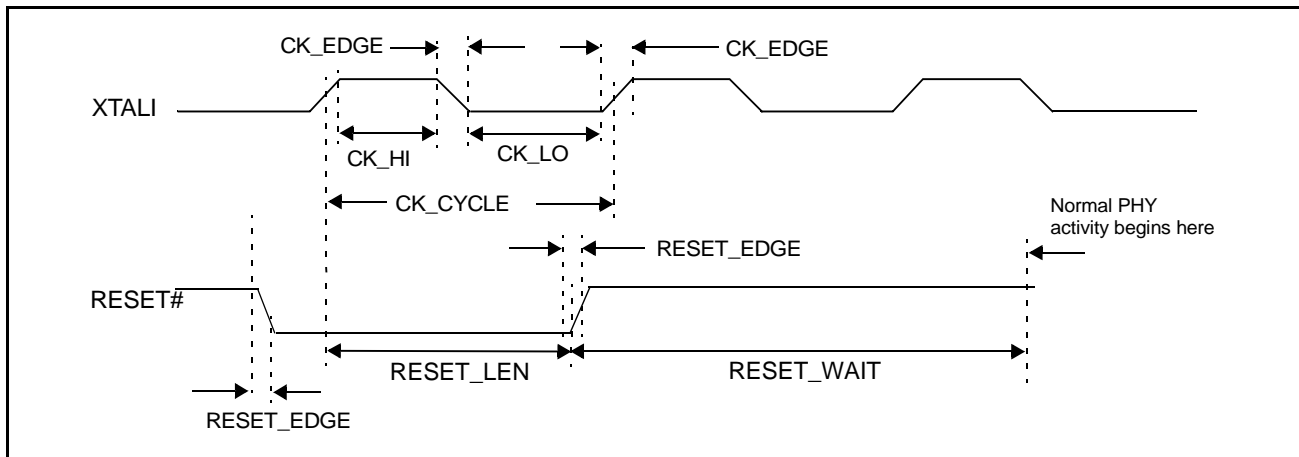

Figure 3: Clock and Reset Timing

Table 40 provides the parameters for 100BASE-X transmit timing. Figure 4 illustrates the 100BASE-TX transmit start of packet timing and Figure 5 on page 61 shows the 100BASE-TX transmit end of packet timing.

Table 40: MII 100BASE-X Transmit Timing

PARAMETER	SYMBOL	MIN	TYP	MAX	UNIT
TXC Cycle Time			40		ns
TXC High/Low Time		16	20	24	ns
TXC Rise/Fall Time		2		5	ns
TXEN, TXD[3:0] Setup Time to TXC rising	TXEN_SETUP	10			ns
TXEN, TXD[3:0] Hold Time from TXC rising	TXEN_HOLD	0			ns
TD± after TXEN Assert (unsampled)	TXEN_TDATA		100		ns
TXD to TD± Steady State Delay	TXD_TDATA		100		ns
CRS Assert after TXEN Assert	TXEN_CRIS		11		ns
CRS Deassert after TXEN Deassert	TXEN_CRIS_EOP		11		ns
COL Assert after TXEN Assert (while RX)	TXEN_COL		17		ns
COL Deassert after TXEN Deassert (while RX)	TXEN_COL_EOP		17		ns

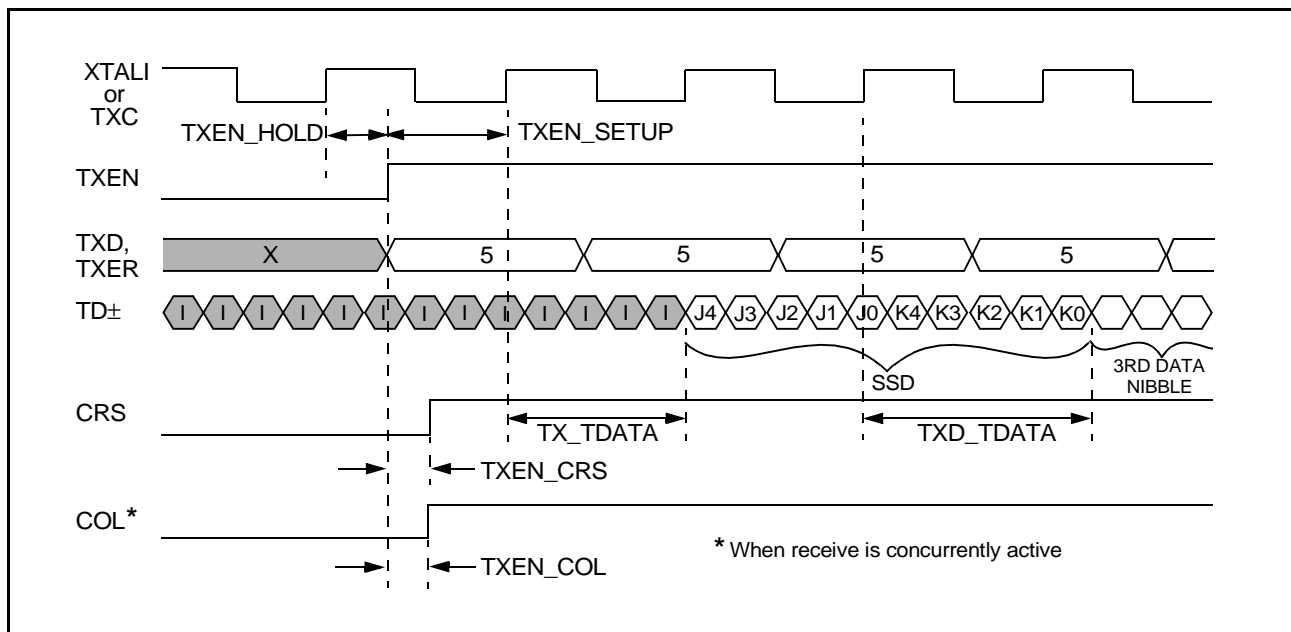

Figure 4: MII Transmit Start of Packet Timing (100BASE-TX)

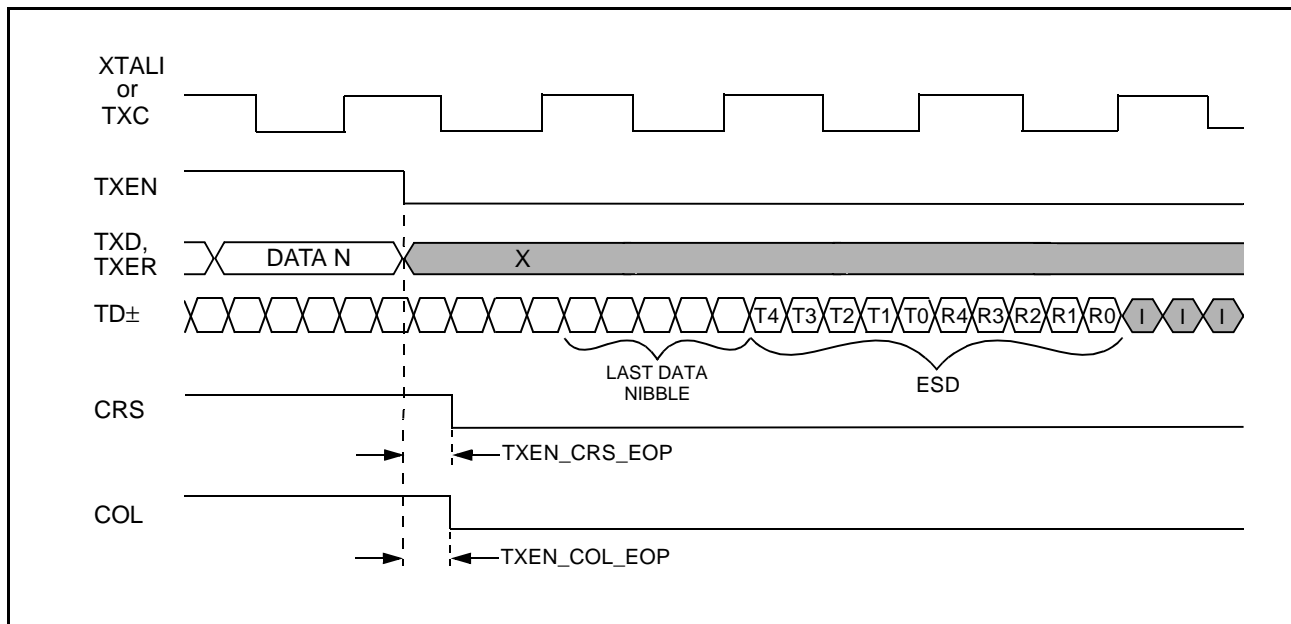

Figure 5: MII Transmit End of Packet Timing (100BASE-TX)

Table 41 below provides 10BASE-X receive timing parameters. See Figure 6 on page 63 and Figure 7 on page 63 for illustrations of 100BASE-TX receive start of packet timing parameters and 100BASE-TX receive end of packet timing. Figure 8 on page 64 shows 100BASE-TX receive packet premature end. See Figure 9 on page 64 for an illustration of link failure or stream cipher error during receive packet. 100BASE-TX False carrier sense timing is shown in Figure 10 on page 65.

Table 41: MII 100BASE-X Receive Timing

PARAMETER	SYMBOL	MIN	TYP	MAX	UNIT
RXC Cycle Time			40		ns
RXC High/Low Time (RXDV asserted)			20		ns
RXC High Time (RXDV deasserted)			20		ns
RXC Low Time (RXDV deasserted)			20		ns
RXC Rise/Fall Time		2		5	ns
RXDV, RXER, RXD[3:0] Delay from RXC falling		-4		4	ns
CRS Deassert from RXC falling (valid EOP only)			1		ns
CRS Assert after RD±	RX_CRS		130		ns
CRS Deassert after RD± (valid EOP)	RX_CRS_EOP		170		ns
CRS Deassert after RD± (premature end)	RX_CRS_IDLE		165		ns
RXDV Assert after RD±	RX_RXDV		165		ns
RXDV Deassert after RD± (valid EOP)	RX_RXDV_EOP		170		ns
RXDV Assert after CRS			40		ns
RD± to RXD Steady State Delay	RX_RXD		170		ns
COL Assert after RD± (while TX)	RX_COL		125		ns
COL Deassert after RD± (valid EOP)	RX_COL_EOP		175		ns
COL Deassert after RD± (premature end)	RX_COL_IDLE		165		ns
Note: RXC minimum high and low times are guaranteed when RXEN is asserted or deasserted. The MII port will always tristate while RXEN is low.					



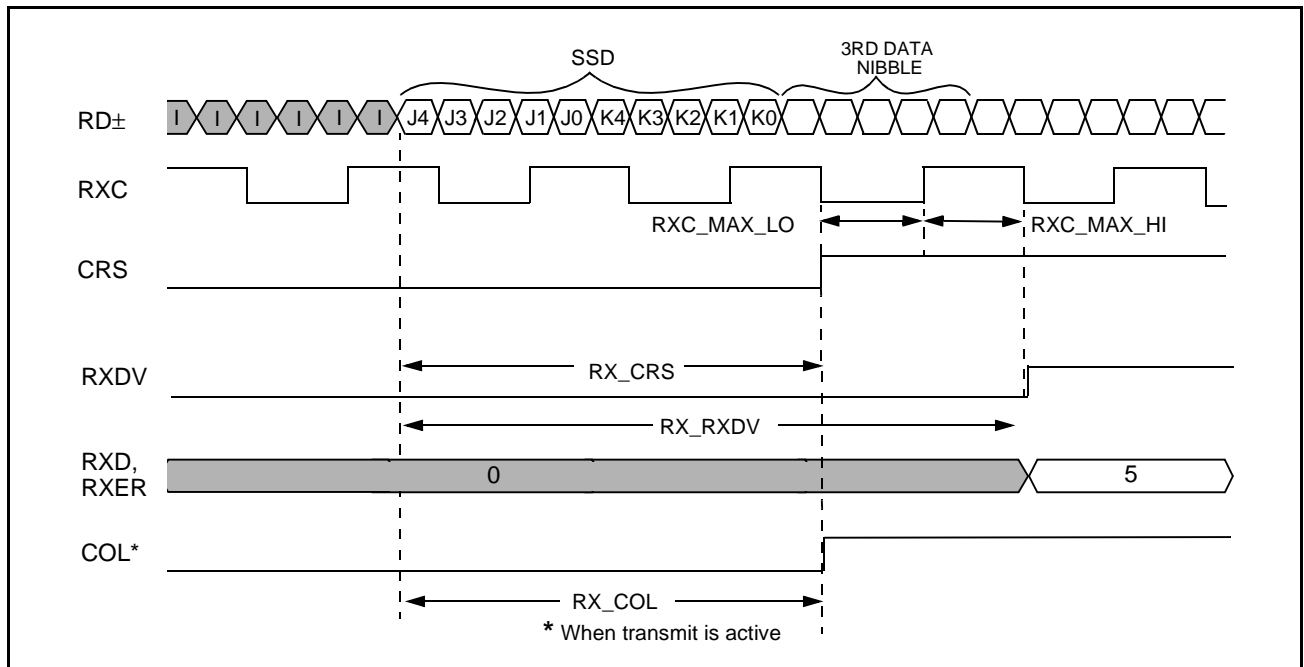

Figure 6: MII Receive Start of Packet Timing (100BASE-TX)

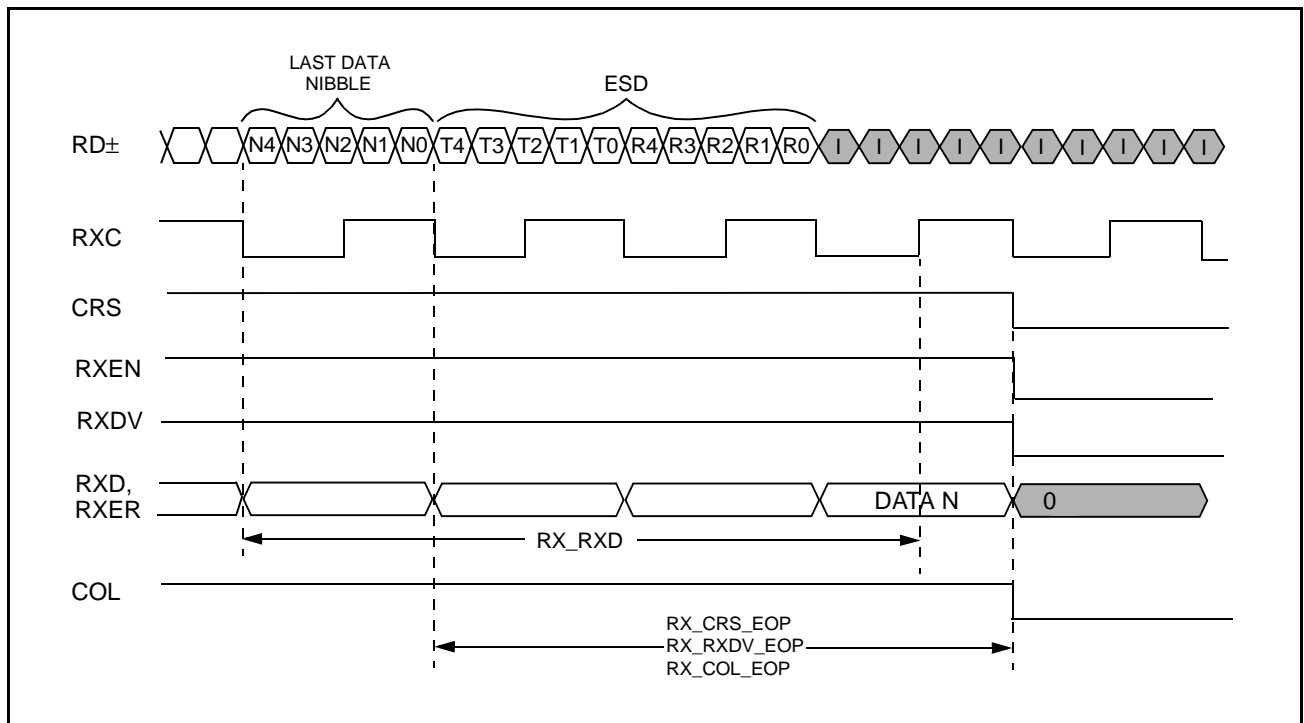

Figure 7: MII Receive End of Packet Timing (100BASE-TX)

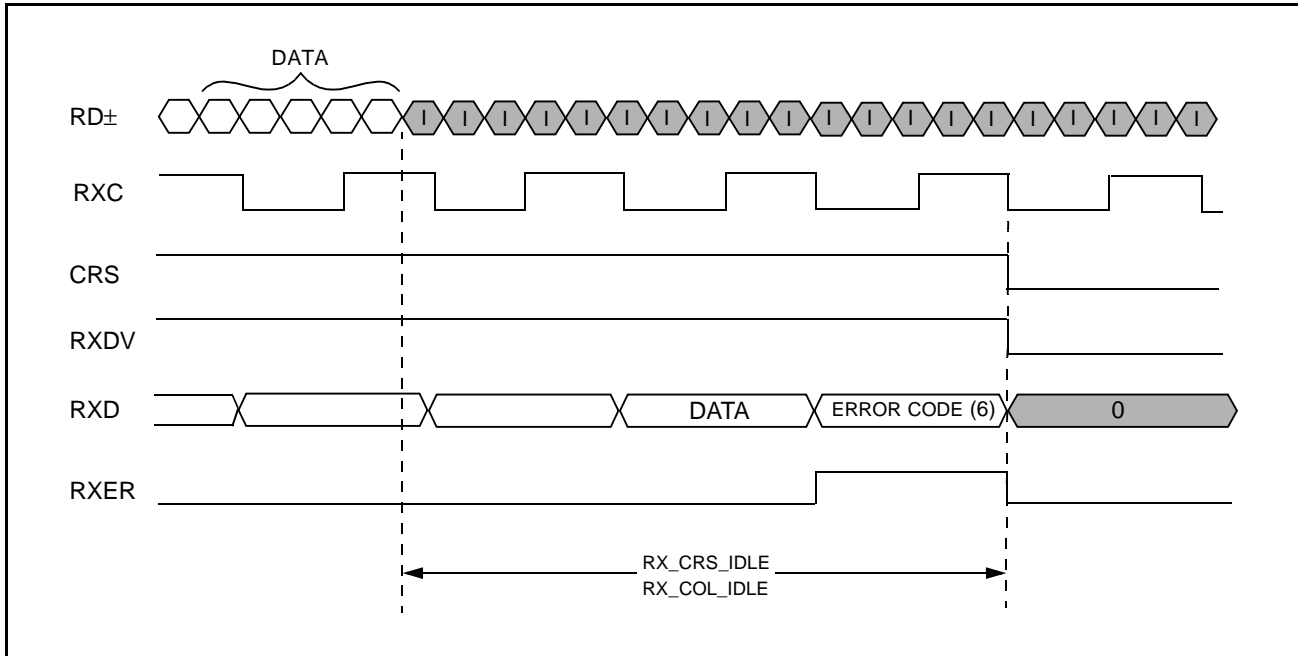

Figure 8: MII Receive Packet Premature End (100BASE-TX)

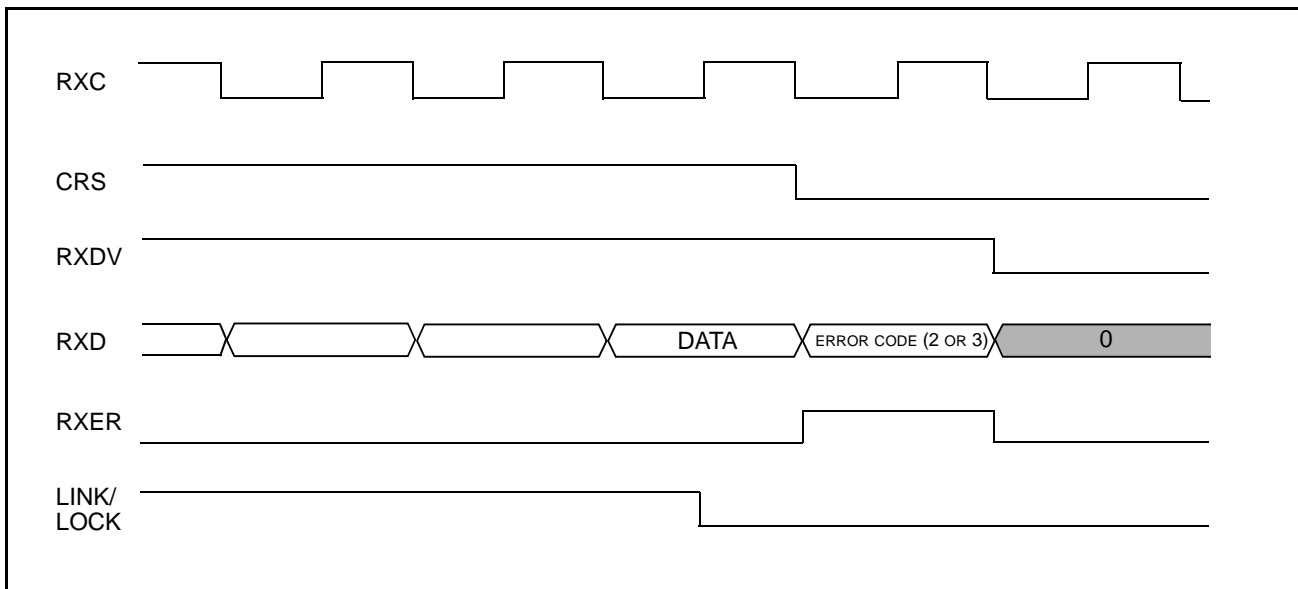

Figure 9: MII Link Failure or Stream Cipher Error During Receive Packet



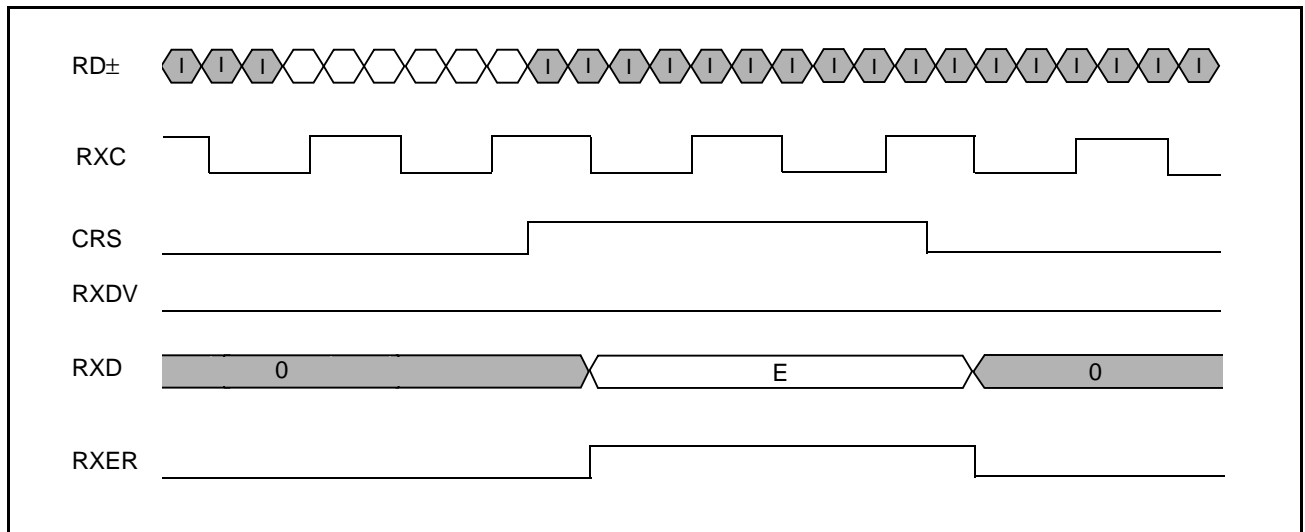

Figure 10: MII False Carrier Sense Timing (100BASE-TX)

Table 42 provides the parameters for 10BASE-T transmit timing. Figure 11 illustrates 10BASE-T transmit start of timing packet.

Table 42: MII 10BASE-T Transmit Timing

PARAMETER	SYMBOL	MIN	TYP	MAX	UNIT
TXC Cycle Time (10BASE-T)	TXC_CYCLE	395	400	405	ns
TXC High/Low Time (10BASE-T)		197.5	200	202.5	ns
TXC Rise/Fall Time		2		5	ns
TXC Rising edge to TXEN valid	TXC_TXEN_VALID			25	ns
TXC Rising edge to TXEN hold	TXC_TXEN_HOLD	75			ns
TXC Rising edge to TXD valid	TXC_TXD_VALID			25	ns
TXC Rising edge to TXD hold	TXC_TXD_HOLD	75			ns
TD± after TXEN Assert	TXEN_TDATA		400		ns
CRS Assert after TXEN Assert	TXEN_CRIS		60		ns
CRS Deassert after TXEN Deassert	TXEN_CRIS_EOP		60		ns
Idle on Twisted Pair after TXEN De-Assert (sampled)	TX_QUIET		400		ns

Note: TXD, TXEN delivered to the BCM5221 should be generated of the rising edge of TXC.

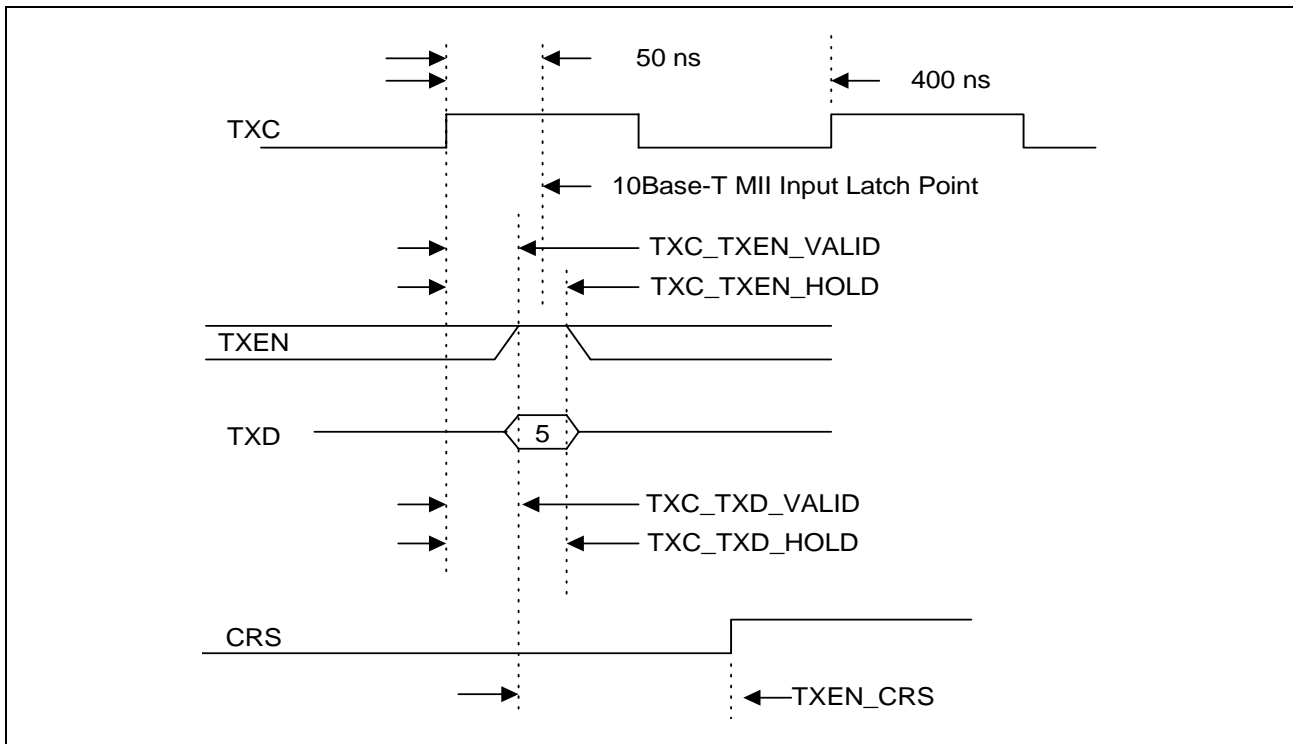

Figure 11: MII 10BASE-T Transmit Start of Packet Timing



Table 43 provides the parameters for MII 10BASE-T receive timing. MII 10BASE-T collision timing is shown in Table 44.

Table 43: MII 10BASE-T Receive Timing

PARAMETER	SYMBOL	MIN	TYP	MAX	UNIT
RXC Cycle Time	RXC_CYCLE		400		ns
RXC High/Low Time			200		ns
CRS Assert after Receive Analog Data	RX_CRD_BT		230		ns
RXC Valid after CRS Assert	RXC_VALID		1.7		μs
RXDV Assert after Receive Analog Data	RX_RXDV		1.2		μs
RXDV Deassert after Receive Analog EOP ends	RX_NOT_RXDV		400		ns
CRS Deassert after Receive Analog EOP ends	RX_NOT_CRD		400		ns

Table 44: MII 10BASE-T Collision Timing

PARAMETER	SYMBOL	MIN	TYP	MAX	UNIT
COL Assert after Receive Analog (while transmitting)	RX_COL		220		ns
COL Deassert after TXEN Deassert (while receiving)	TXEN_NOT_COL		400		ns
COL Assert after TXEN Assert (while receiving)	TXEN_COL		50		ns
COL Deassert after Receive Analog ends (while transmitting)	RX_NOT_COL		200		ns

Table 45 provides the parameters for 10BASE-T serial transmit timing. Figure 12 illustrates 10BASE-T serial transmit start of timing packet.

Table 45: 10BASE-T Serial Transmit Timing

PARAMETER	SYMBOL	MIN	TYP	MAX	UNIT
TXC Cycle Time	TXC	95	100	105	ns
TXC Low Time	TXC_LO	97.5		102.5	ns
TXC High Time	TXC_HIGH				
TXC Rise Time	TXC_RISE	2		5	ns
TXC Fall Time	TXC_FALL				
TXEN, TXD0 to TXC Rising	TXEN_SETUP	10			ns
TXEN, TXD0 Hold after TXC Rising	TXEN_HOLD	0			ns
TXEN to TD± Start	TXEN_TXDATA		350		ns
TXEN to TD± End	TXEN_QUIET		400		ns

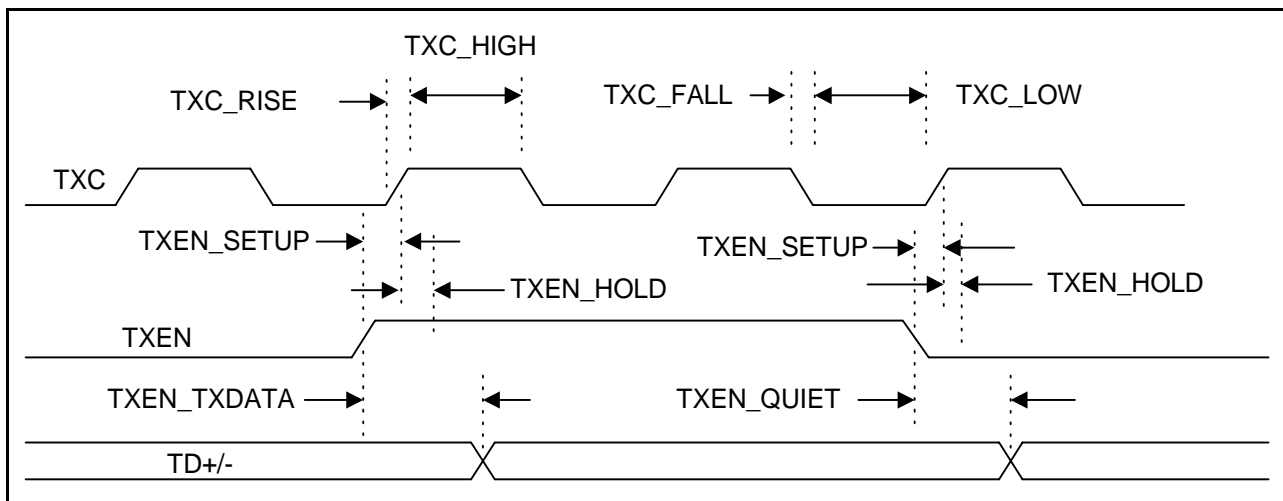

Figure 12: 10BASE-T Serial Transmit Timing

Table 46 provides the parameters for 10BASE-T serial receive timing. Figure 13 illustrates 10BASE-T serial receive start of timing packet.

Table 46: 10BASE-T Serial Receive Timing

PARAMETER	SYMBOL	MIN	TYP	MAX	UNIT
RXC to RXD0 Output Delay	RXD_DELAY			5	ns
CRS Assert after RD±	RX_CRS_DV		220		ns
CRS Deassert after RD±, valid EOP	RX_NOT_CRS		270		ns

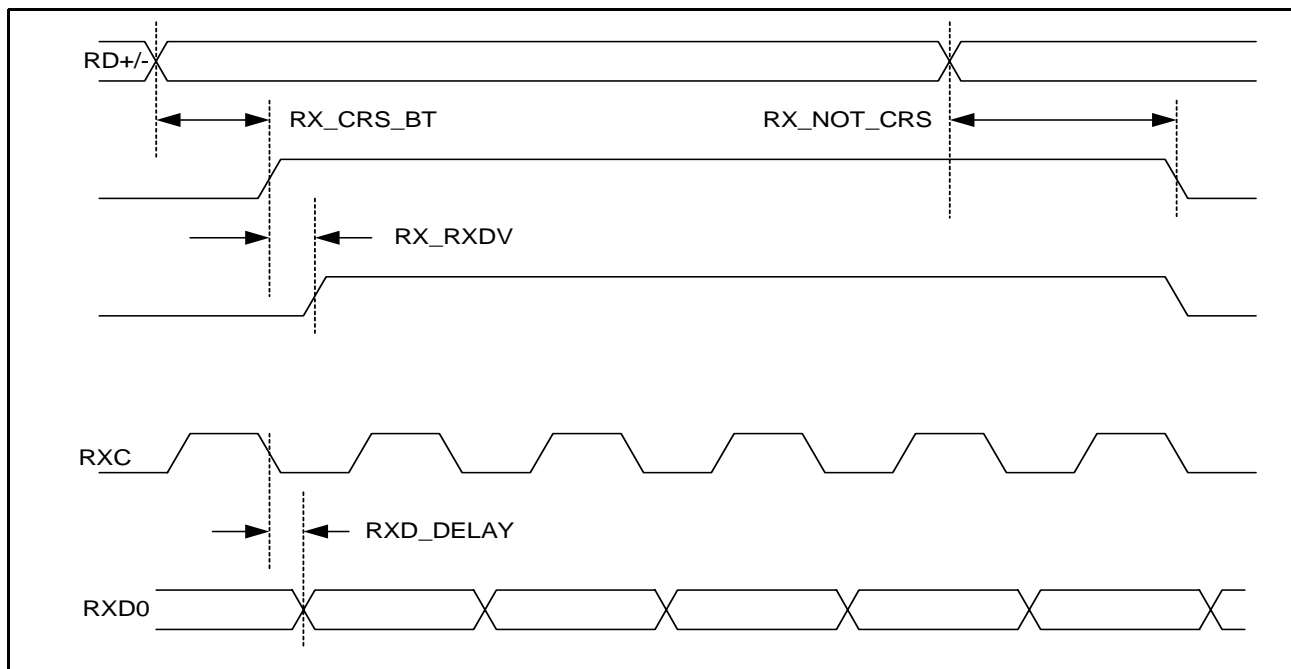

Figure 13: 10BASE-T Serial Receive Timing

Table 47, Table 48, and Table 49 provide the parameters for loopback timing, auto-negotiation timing, and LED timing.

Table 47: Loopback Timing (MII)

PARAMETER	SYMBOL	MIN	TYP	MAX	UNIT
TXD to RXD Steady State Propagation Delay			184		ns

Table 48: Auto-Negotiation Timing

PARAMETER	SYMBOL	MIN	TYP	MAX	UNIT
Link Test Pulse Width			100		ns
FLP Burst Interval			16		ms
Clock Pulse to Clock Pulse			123		μs
Clock Pulse to Data Pulse (Data = 1)			62.5		μs

Table 49: LED Timing

PARAMETER	SYMBOL	MIN	TYP	MAX	UNIT
LED On Time (XMTLED#, RCVLED#, ACTLED#)			80		ms
LED Off Time (XMTLED#, RCVLED#, ACTLED#)			80		ms



Management data interface timing parameters are described in Table 50. Figure 14 and Figure 15 illustrate two types of management interface timing.

Table 50: Management Data Interface Timing

PARAMETER	SYMBOL	MIN	TYP	MAX	UNIT
MDC Cycle Time		40			ns
MDC High/Low		20			ns
MDC Rise/Fall Time				10	ns
MDIO Input Setup Time to MDC rising		10			ns
MDIO Input Hold Time from MDC rising		10			ns
MDIO Output Delay from MDC rising		0		30	ns

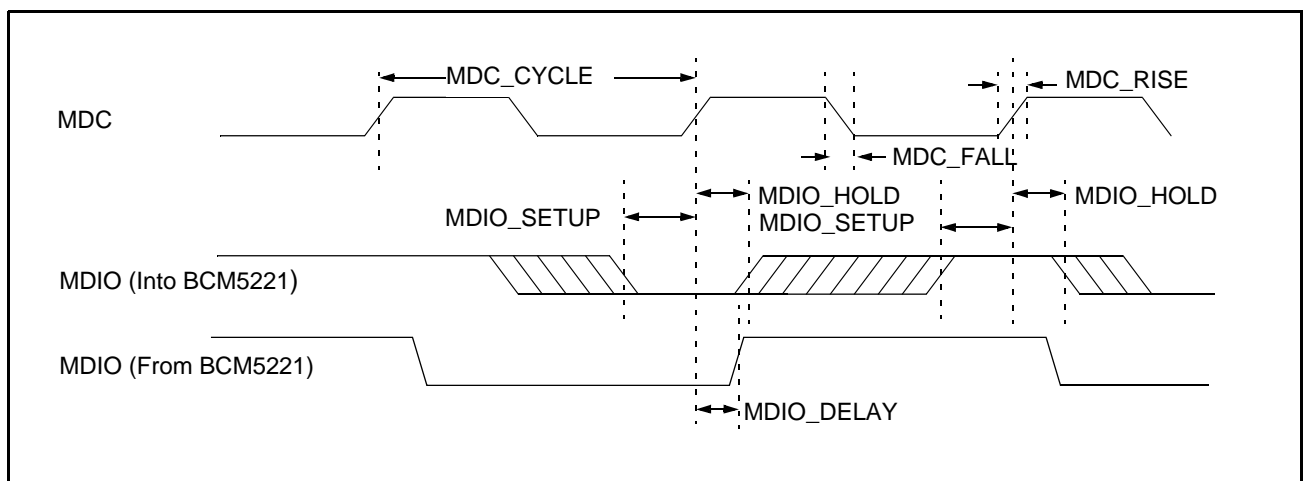

Figure 14: Management Interface Timing

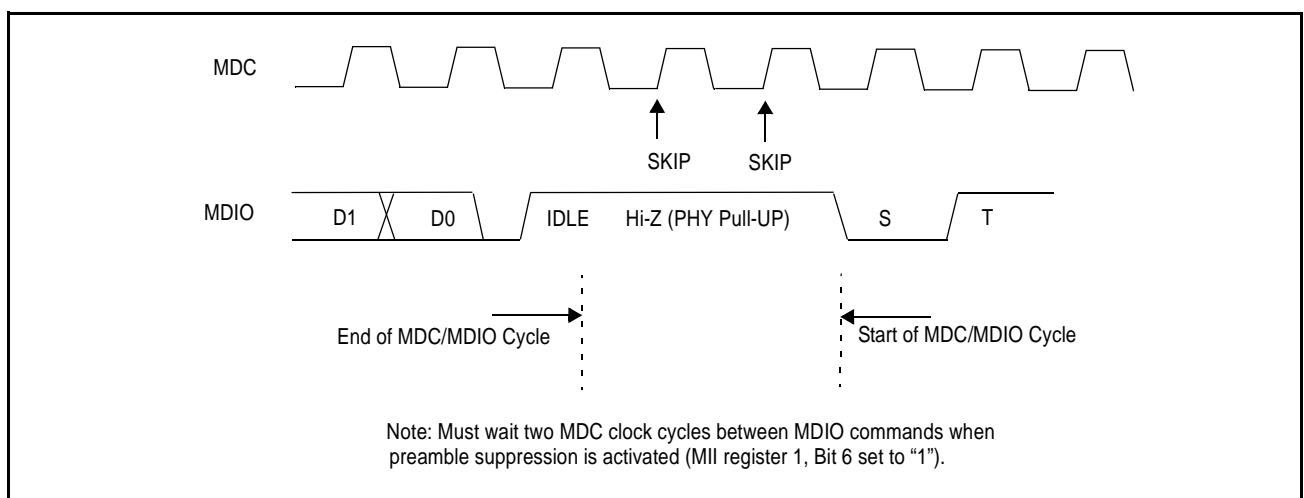

Figure 15: Management Interface Timing (with Preamble Suppression On)



RMII transmit timing parameters are described in Table 51 and Figure 16 illustrates the RMII management transmit timing.

Table 51: RMII Transmit Timing

PARAMETER	SYMBOL	MIN	TYP	MAX	UNIT
REF_CLK Cycle Time			20		ns
TXEN, TXER, TXD[1:0] Setup Time to REF_CLK rising	TXEN_SETUP	4			ns
TXEN, TXER, TXD[1:0] Hold Time from REF_CLK rising	TXEN_HOLD	2			ns

Notes:

1. TXD[1:0] provides valid data for each REF_CLK period while TX_EN is asserted.
2. As the REF_CLK frequency is 10 times the data rate in 10Mbps mode, the value on TXD[1:0] is valid so that TXD[1:0] can be sampled every 10th cycle, regardless of the starting cycle within the group, and yield the correct frame data.

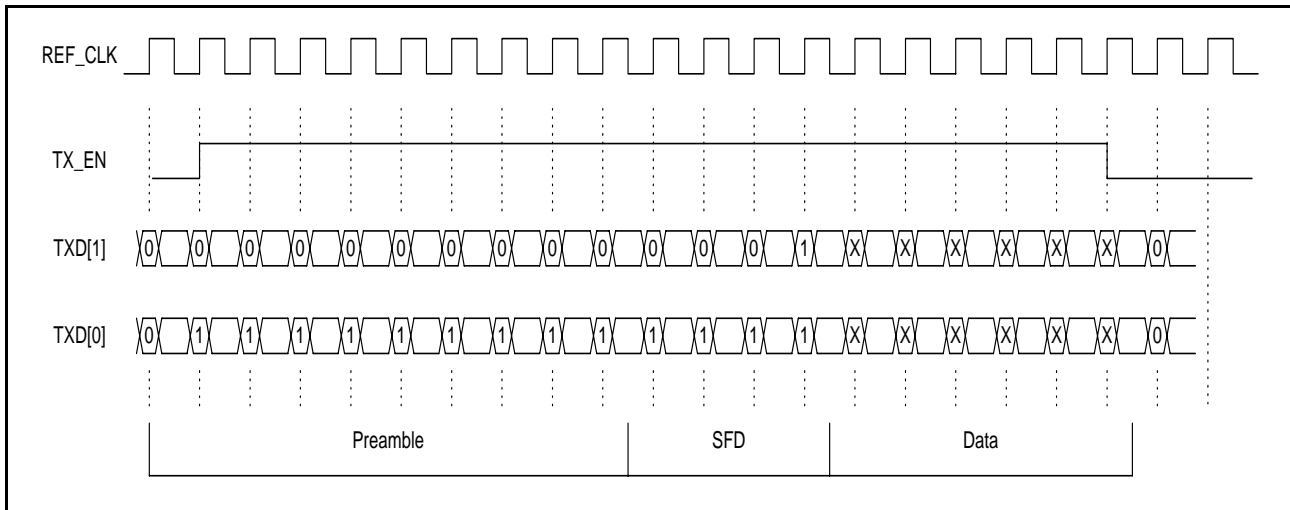

Figure 16: RMII Transmit Packet Timing

RMII receive timing parameters are described in Table 52 and Figure 17 illustrates the RMII management receive timing.

Table 52: RMII Receive Timing

PARAMETER	SYMBOL	MIN	TYP	MAX	UNIT
REF_CLK Cycle Time			20		ns
RXD[1:0], RXER, CRS_DV Output delay from REF_CLK Rising		2		14	ns

Notes:

1. As the REF_CLK frequency is 10 times the data rate in 10Mbps mode, the value on RXD[1:0] is valid so that RXD[1:0] can be sampled every 10th cycle, regardless of the starting cycle within the group, and yield the correct frame data.
2. The receiver accounts for differences between the local REF_CLK and the recovered clock through use of sufficient elasticity buffering.
3. The output delay is with a load of 25 PF, which accommodates a PCB trace length of over 12 inches.

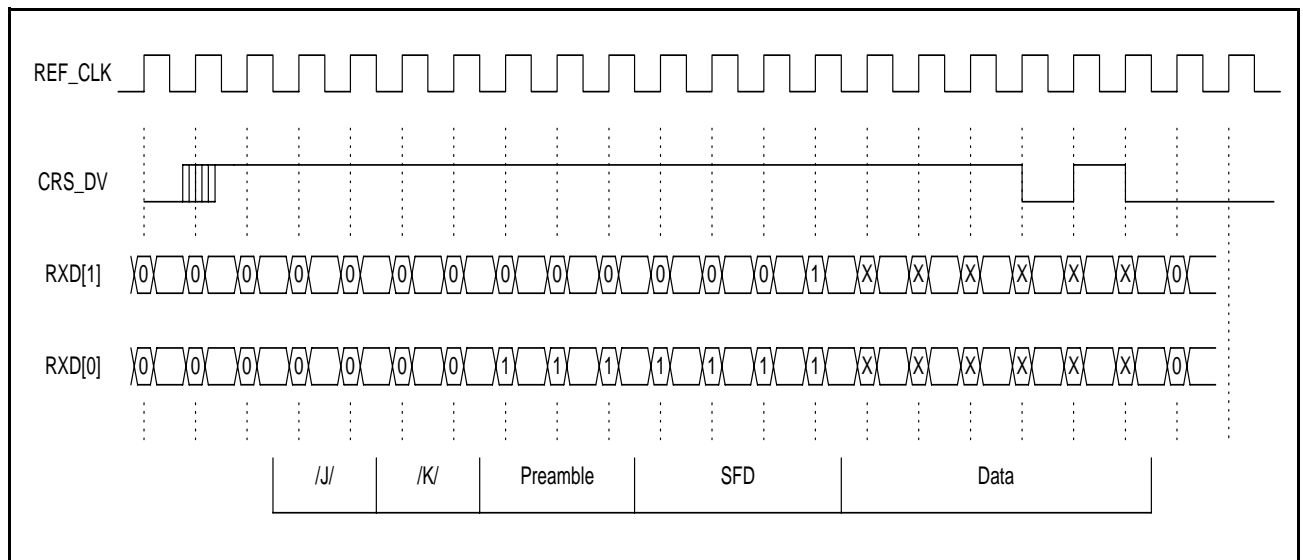

Figure 17: RMII Receive Packet Timing

Table 53 describes the RMI 100BASE-X propagation delay timing parameters, and Table 54 describes the RMI 10BASE-T propagation delay timing parameters.

Table 53: RMI 100BASE-X Propagation Delay Timing

PARAMETER	SYMBOL	MIN	TYP	MAX	UNIT
TD± after TXEN Assert	TXEN_TDATA		89		ns
TXD to TD± Steady State Delay	TXD_TDATA		95		ns
CRS_DV Assert after RD±	RX_CRS_DV		124		ns
CRS_DV Deassert after RD±, premature end	RX_CRS_DV		164		ns
CRS_DV Deassert after RD±, valid EOP	RX_CRS_DV_EOP		237		ns

Table 54: RMI 10BASE-T Propagation Delay Timing

PARAMETER	SYMBOL	MIN	TYP	MAX	UNIT
TD± after TXEN Assert (sampled)	TXEN_TDATA		585		ns
CRS_DV Assert after RD±	RX_CRS_DV		220		ns



Section 7: Electrical Characteristics

Table 55 provides the absolute maximum ratings for the BCM5221. The recommended operating conditions for the BCM5221 are shown in Table 56. Table 57 on page 76 gives the electrical characteristics of the BCM5221.

Table 55: Absolute Maximum Ratings

SYMBOLS	PARAMETERS		MIN	MAX	UNITS
V_{DD}	Supply voltage	REGDVDD, REGAVDD, OVDD	GND - 0.3	3.60	V
		DVDD, AVDD, BIASVDD	GND - 0.3	2.75	V
V_I	Input voltage		GND - 0.3	OVDD + 0.3	V
I_I	Input current			±10	mA
T_{STG}	Storage temperature		-40	+125	°C

Note: These specifications indicate levels where permanent damage to the device may occur. Functional operation is not guaranteed under these conditions. Operation at absolute maximum conditions for extended periods may adversely affect long-term reliability of the device

Table 56: Recommended Operating Conditions for BCM5221

SYM	PARAMETER	PIN	OPERATING MODE	MIN	MAX	UNITS
V_{DD}	Supply voltage BCM5221	REGDVDD, REGAVDD, OVDD		3.00	3.60	V
		DVDD, AVDD, BIASVDD		2.375	2.625	V
V_{IH}	High-level input voltage	All digital inputs		2.0	OVDD	V
V_{IL}	Low-level input voltage	All digital inputs			0.8	V
		SD±	100BASE-TX		0.4	V
V_{IDIFF}	Differential input voltage	RD±, SD±	100BASE-FX	150		mV
V_{ICM}	Common mode input voltage	RD±	100BASE-TX	1.85	2.05	V
		RD±, SD±	100BASE-FX	1.85	2.05	V
T_A	Ambient operating temperature			-40	85	°C

Table 57: Electrical Characteristics

SYM	PARAMETER	PINS	CONDITIONS	MIN	TYP	MAX	UNITS
I _{DD}	Supply current	AVDD, DVDD, OVDD	100BASE-TX		110		mA
I _{DD}	Supply current low power mode	AVDD, DVDD, OVDD	CLOCK ON ENERGY DET ON		12		mA
I _{DDQ}	Supply current power off mode	AVDD, DVDD, OVDD	Hardware/Software		3		mA
V _{OH}	High-level output voltage	All digital outputs	I _{OH} = -12 mA	OVDD-0.5			V
		TD±	driving loaded magnetics module			AVDD+1.5	V
V _{OL}	Low-level output voltage	All digital outputs	I _{OL} = 8 mA			0.4	V
		TD±	driving loaded magnetics module	AVDD-1.5			V
V _{ODIFF}	Differential output voltage	TD±	100BASE-FX mode	400			mV
I _I	Input current	Digital inputs w/ pull-up resistors	V _I = OVDD			+100	μA
			V _I = DGND			-200	μA
		Digital inputs w/ pull-down resistors	V _I = OVDD			+200	μA
			V _I = DGND			-100	μA
		All other digital inputs	DGND ≤ V _I ≤ OVDD			±100	μA
I _{OZ}	High-impedance output current	All three-state outputs	DGND ≤ V _O ≤ OVDD				μA
		All open-drain outputs	V _O = OVDD				μA
V _{BIAS}	Bias voltage	RDAC		1.18		1.30	V

Section 8: Application Example

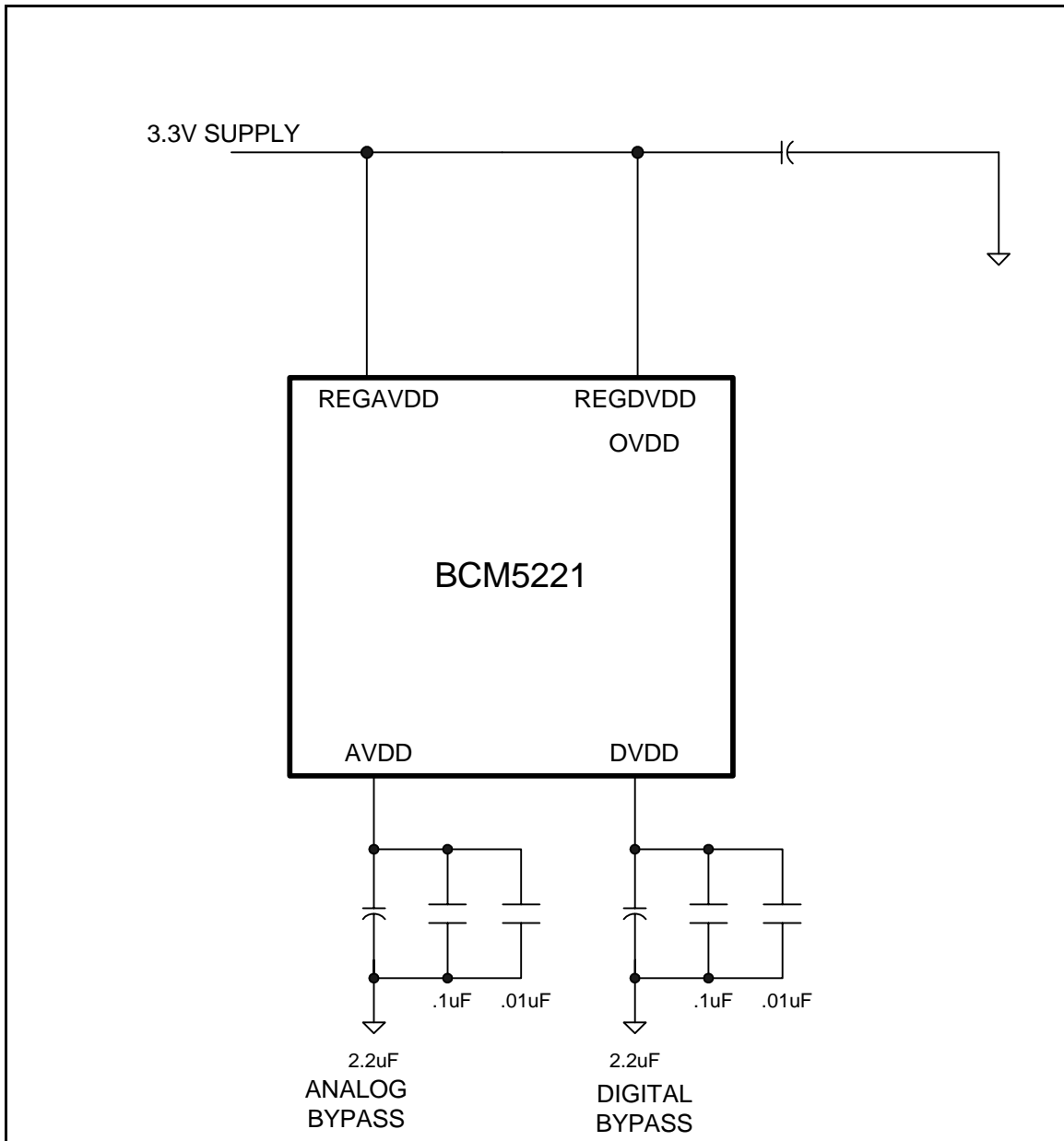

Figure 18: Power Connections BCM5221 (3.3V)

Section 9: Thermal Characteristics

Table 58: θ_{JA} vs. Airflow for the BCM5221KPB(FBGA 64)

AIRFLOW (feet per minute)	0	100	200	400	600
Theta - J_A (°C/W)	35.15	25.57	22.99	20.88	20.30

Theta JC for this package in still air is 21.23 °C/W. The BCM5221KPB is designed and rated for a maximum junction temperature of 125 °C.

Table 59: θ_{JA} vs. Airflow for the BCM5221KPT(64 TQFP)

AIRFLOW (feet per minute)	0	100	200	400	600
Theta - J_A (°C/W)	56.4	51.9	49.9	48.2	47.2

Theta JC for this package in still air is 18.5°C/W. The BCM5221KPT is designed and rated for a maximum junction temperature of 125°C.

Section 10: Mechanical Information

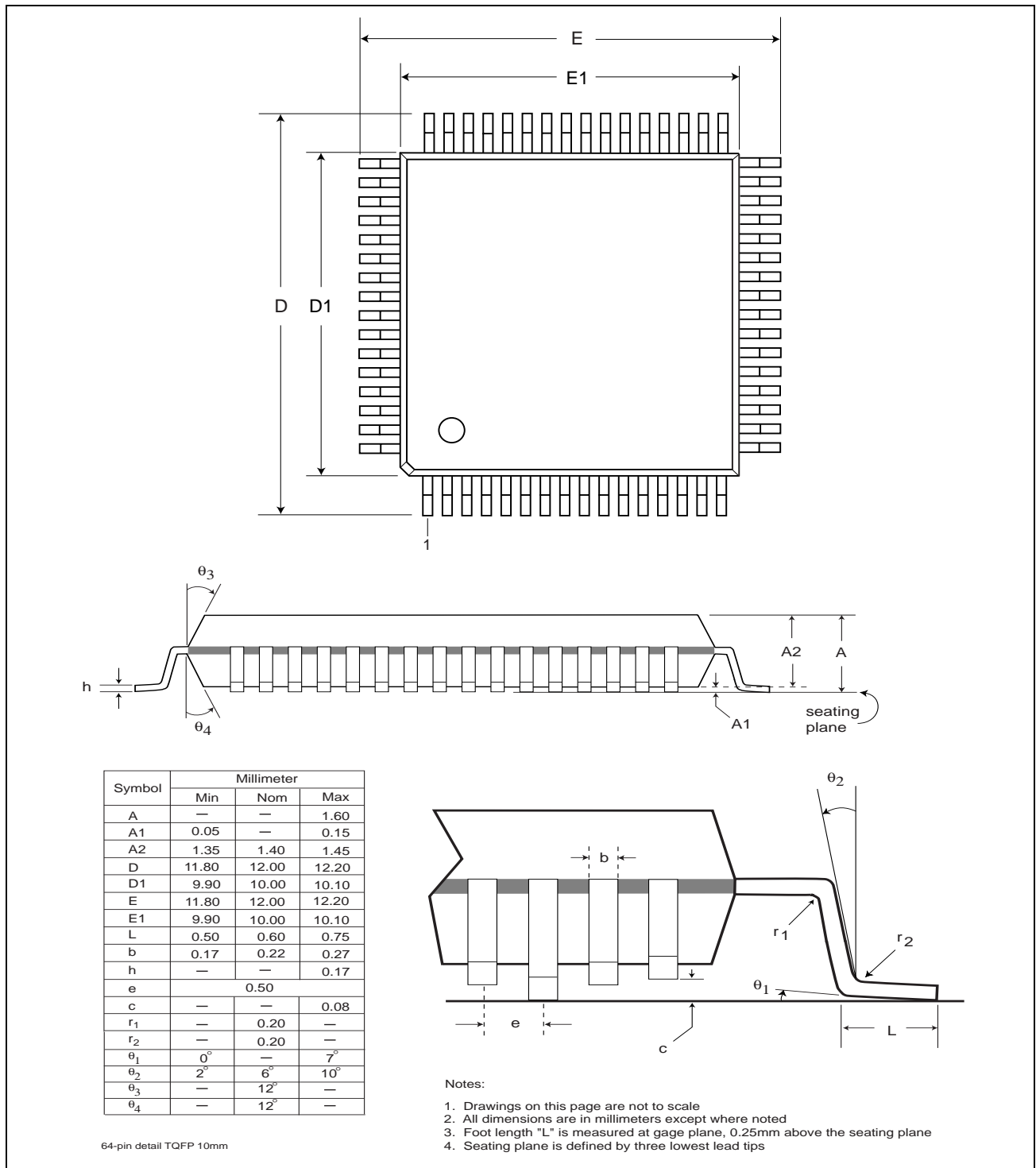

Figure 19: 64-Pin TQFP 10mm Package (BCM5221 KPT)

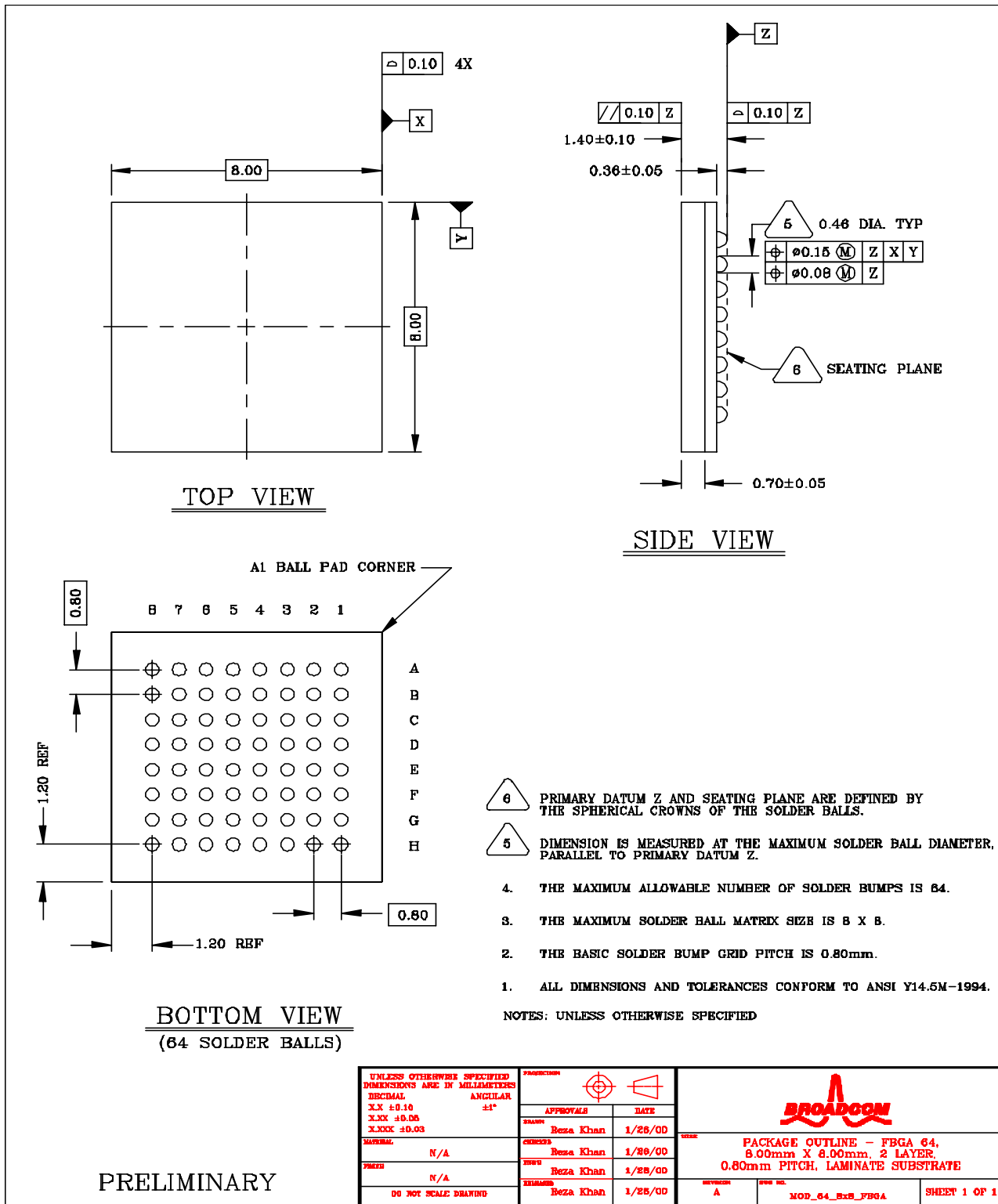

Figure 20: FBGA 64, 8mmx8mm (BCM5221 KP)

Section 11: Ordering Information

<i>PART NUMBER</i>	<i>PACKAGE</i>	<i>AMBIENT TEMPERATURE</i>
BCM5221KPT	64-TQFP 10mm package	-40° to 85° C
BCM5221KPB	FBGA 64, 8mm x 8mm	-40° to 85° C

Note

Specific revisions of the BCM5221 are qualified for operations over 0° C to 70° C and -40° to 85° C.

Broadcom Corporation

16215 Alton Parkway
P.O. Box 57013
Irvine, California 92619-7013
Phone: 949-450-8700
Fax: 949-450-8710

Broadcom® Corporation reserves the right to make changes without further notice to any products or data herein to improve reliability, function, or design. Information furnished by Broadcom Corporation is believed to be accurate and reliable. However, Broadcom Corporation does not assume any liability arising out of the application or use of this information, nor the application or use of any product or circuit described herein, neither does it convey any license under its patent rights nor the rights of others.