

FE-card (for TB2002) ⇒ FE-emulator

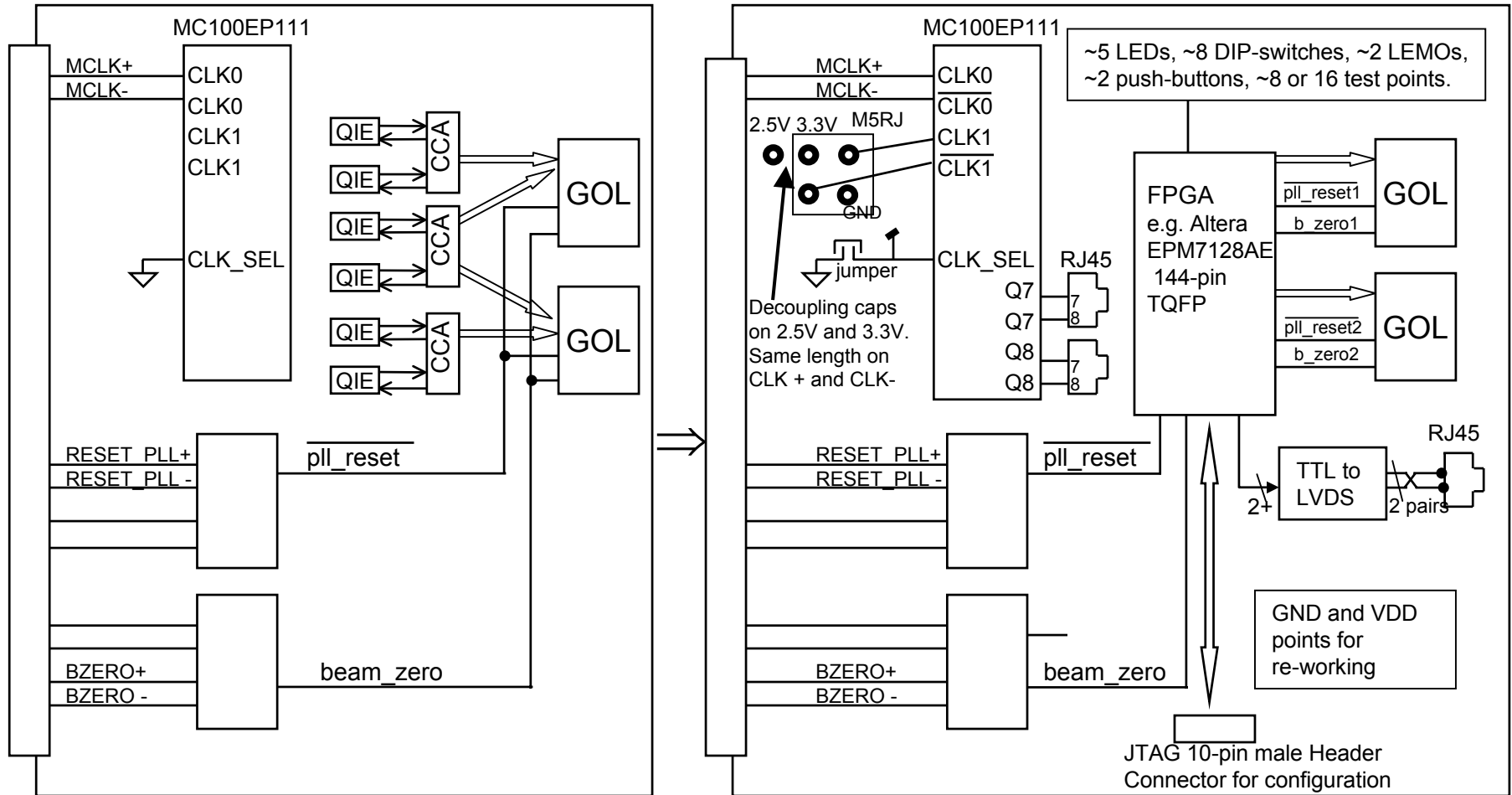

This scheme indicates only the changes from the FE-card to the FE-emulator. Things non indicated remain the same (possibly with the same layout). Also same form factor for the board.

FE-emulator can operate in the crate and stand-alone: need easy connections to power supplies.

List of changes: Crystal, RJ45 outputs, FPGA, the signals *beam_zero* and *pll_reset* pass through the FPGA, TTL-to-LVDS outputs.

JTAG connector 1=TCK, 2=GND, 3= TDO, 4=VCC, 5=TMS, 6,7,8 n.c., 9=TDI, 10=GND.