

Experiment 4

Reflection and Refraction of Light – Curved Surfaces

1 Introduction

In this experiment, we will continue to explore geometrical optics by studying the optics of simple curved mirrors and lenses. More specifically, we will study a concave mirror and double concave and double convex lenses.

2 Background

2.1 Mirrors

When studying the geometrical optics of mirrors, one considers the following three quantities: object distance s_o , image distance s_i , and focal length f . For a mirror, these quantities are related by the equation

$$\frac{1}{s_o} + \frac{1}{s_i} = \frac{1}{f} \quad (1)$$

where the focal length of the mirror is related to the radius of curvature, R , by $R = 2f$. In this experiment, we will study a concave mirror. For this type of mirror it is helpful to note that $s_o > 0$, $f > 0$, and $R > 0$; $s_i > 0$ corresponds to a real image and $s_i < 0$ corresponds to a virtual image. In Fig. 1, positive values for s_o , f and s_i are to the right of the mirror.

2.2 Thin Lenses

When studying geometrical optics for thin lenses, one is concerned with the same quantities mentioned above for mirrors. Equation (1) also holds for lenses. In this case,

$$\frac{1}{f} = (n - 1) \left(\frac{1}{R_1} - \frac{1}{R_2} \right), \quad (2)$$

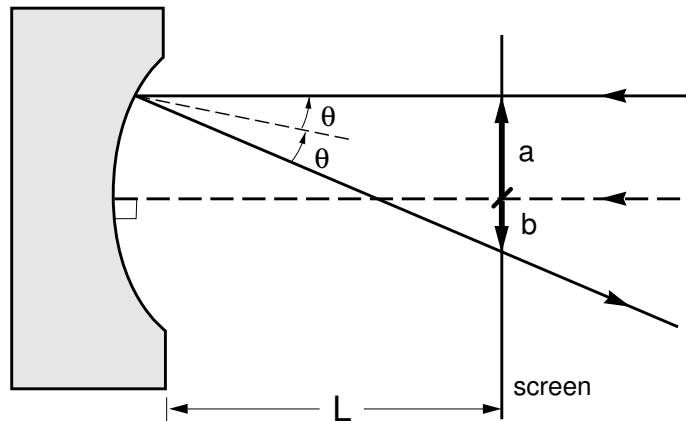

Figure 1: Experimental set up to determine radius of curvature of the concave mirror. An incoming ray that is parallel to and above the optical axis (dashed line) crosses the optical axis at the focal point.

relates the focal length to the index of refraction of the lens medium, n , and to the radii of curvature of the front (entrance), R_1 , and back, R_2 , surfaces of the lens. The following sign conventions have generally been adopted for lenses. For a double concave lens $R_1 < 0$, $R_2 > 0$, and $f < 0$. For a double convex lens $R_1 > 0$, $R_2 < 0$, and $f > 0$. If one side of the lens is flat this corresponds to $R = \infty$.

3 Experiment

3.1 The Concave Mirror

In this experiment, we will determine the focal length of the concave mirror in three different ways.

3.1.1 Capturing a Real Image

First, take the concave mirror out into the hallway. Point your mirror at one of the windows and capture the image of the scene on a piece of paper. If you assume that the window is located approximately at ∞ , Eq. (1) places the image at the focal length. Note this distance because this is approximately what you should be getting for the rest of the experiments with this mirror. Estimate the uncertainty in this value of the focal length.

3.1.2 Tracing Rays

In the second methods you will determine the focal length by tracing the rays with a laser beam. To start, project the laser beam parallel to the optical axis of the mirror and normal to the surface of the mirror as shown by the dashed line in Fig. 1. Align your laser by retro-reflecting

the beam back into the laser. Next, translate the beam a distance a away, parallel to the optical axis. The reflected beam will cross the axis at the focal length. Why? Note, all rays pass through the focal point so as you move the beam up and down, and side to side, look for a spot that does not move. Record this distance and compare it with the result you determined from the first part. Comment on any differences or similarities. Finally, for four or five values for a , measure a and b , and the distance L in Fig. 1. You can calculate the radius of curvature, R , by the equation

$$R = \left(\frac{2a}{a \pm b} \right) L. \quad (3)$$

The plus sign in the denominator is used if, upon translation of the laser beam, points a and b move away from the dotted line in opposite directions. The negative sign should be used if, upon translation of the laser beam, they move away from the dotted line in the same direction. Find the focal length from these measurements. As usual, estimate the uncertainties in all your measurements.

3.1.3 Parallax Image Location

The third way we will determine the focal length of the mirror is by measuring object and image distances. To start, secure the mirror at one end of the optical bench and using one black metal marker with its flat side facing the mirror as an object, find the image position by placing a second marker with its narrow edge facing the mirror at the position of the image of the object as seen in the mirror. The second marker will be in the same position as the image when there is no parallax between the image and the marker.¹

Perform this measurement for four object distances – two for a real image and two for a virtual images. Note, the virtual image is located behind the mirror. Think about where the object must be located, relative to the focal point and the mirror surface, to produce a virtual image. Use your previous measurements and Eq. (1) to estimate the approximate image locations before you begin this part. From the four measurements estimate the focal length.

3.1.4 Best Focal Length Estimate

From the three parts, determine the best value for the focal length of the mirror along with an uncertainty. In your analysis, perform weighted averages to determine the best focal length for each optical element.

¹When no parallax exists, the image of the object (the black marker) and the second marker placed at the apparent image position will move together. You will need to look at the image of the black marker and the second marker at the same time. Be sure not to focus on the black marker itself nor the image of the second marker.

As part of your analysis, discuss which method(s) you believe gave you the most believable results. Support your belief quantitatively.

Use this focal length to make a graphical sketch of where a real and imaginary image will be located and what the corresponding object locations would be. Following Fig. 1 you will need two rays in each case – one that passes through the focal length and one that is parallel to the optical axis. In your notebook tracing the rays from the object to the image. For more information see Ref. [2].

3.2 Double Concave and Double Convex Lenses

In this part of the experiment, you will find the focal length of both the double concave and double convex lenses in several ways. You will use focal lengths to determine the index of refraction of the lens medium.

3.2.1 Focusing Lens

First, take the double convex lens out into the hallway and estimate its focal length as you did for the mirror.

Second, mount the lens in a lens holder and place it in the middle of the optical bench. Align the laser beam to be co-linear with the optical axis of the lens. As you translate the laser up and down and side to side, locate the focal point, F , on the other side of the lens. See Fig. 2. As with the mirror, parallel rays will cross the optical axis at the same place on the optical axis. Measure the focal length, f .

Finally, using one marker as an object, locate the image by placing a second marker so that there is no parallax between it and the image of the object as seen through the lens. As with the mirror, make four or five measurements each for real and virtual images. Again, the virtual image will be located behind the mirror, on the object side. Use Eq. (1) to determine f for the lens. Give your best estimate of the focal length of this lens.

3.2.2 Diverging Lens

The diverging lens is a bit harder to work with because you will not be able to generate a real image. To estimate its focal length, align the laser to be co-linear with the optical axis.² Now, shift the beam parallel to the axis and determine the angle the ray makes with the optical axis after it passes through to the other side of the lens as shown in the Fig. 3. You need to make two measurements of the ray leaving the lens to establish the angle. Use geometry to estimate f . Do this for four

²In this case, you can determine the optical axis by finding the spot on the lens where direction of the laser beam as it passes through the lens is not deviated. You will also need to adjust the orientation of the lens to retro-reflect the beam back onto the laser.

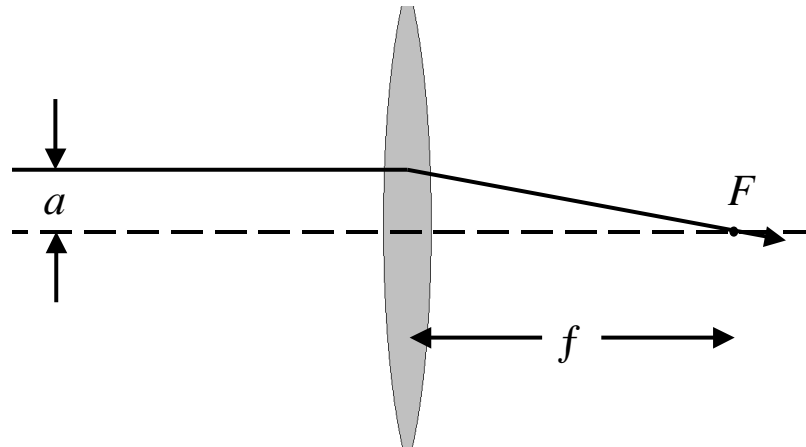

Figure 2: Focusing lens focal length measurement. Locate the focal spot, F , by translating a ray parallel to the optical axis (dashed line). The focal length, f , is approximately independent of a .

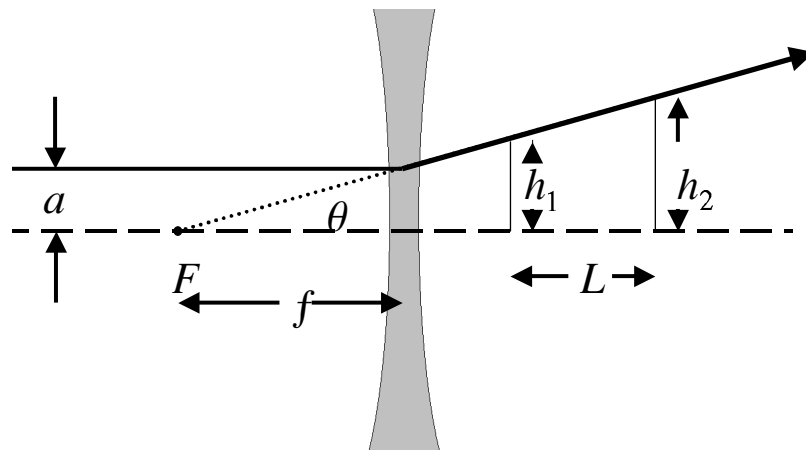

Figure 3: Diverging lens focal length measurement. Locate the focal spot, F , by measuring the angle of the emerging ray that was initially parallel to and a distance a away from the optical axis (dashed line). Note, $\tan \theta = |h_1 - h_2| / L$.

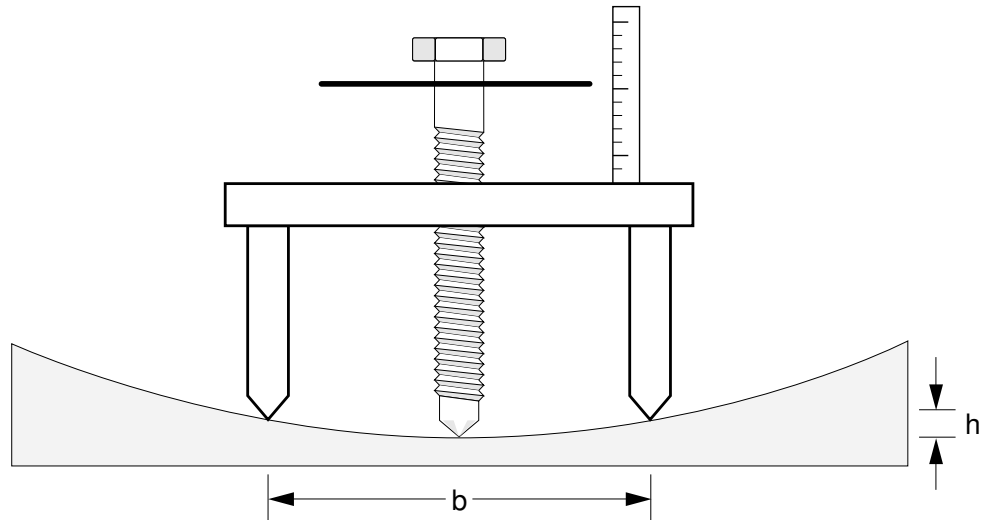

Figure 4: Schematic illustration of how to use a spherometer to measure the radius of curvature of a lens. Note, h measures the difference in the lengths of the center screw and the three feet and b is the length of the side of the triangle formed by the feet. **DO NOT USES THE SPHEROMETER ON THE MIRROR!**

different rays and estimate the focal length and the uncertainty.

Next, mount the double concave lens at one end of the optical bench. As before, use one marker as an object and locate the image with a second marker by removing parallax. Obtain several values of the object distance and corresponding image distance using this method. Note that since the images are always virtual, the image distance will be negative. Give your best estimate of the focal length of this lens.

3.2.3 Spherometer

DO NOT USES THE SPHEROMETER ON THE MIRROR!

Use the spherometer to measure the radii of curvature of each surface of each of the lenses. The configuration is sketched in Fig. 4. First, measure b , the separation of the legs. Next, calibrate the zero point of the dial and screw on a flat surface. Then, determine the radius of curvature R from a measurement of the height h by using the equation

$$R = \frac{b^2/3 + h^2}{2h}. \quad (4)$$

Use this results together with the focal lengths you measured and Eq. (2) to determine n for each lens and the uncertainty in this quantity.

3.2.4 Analysis

Again, use weighted averages to determine the focal lengths in each

case. Discuss which method gives the most believable results. Finally, include in your discussion of the experiment, where the real and virtual images are located and under what conditions (where will the object be located relative to the lens and focal point) you generate real and virtual images for the concave mirror and the convex lens.

For Further Reading:

1. Born, M., and Wolf, E. *Principles of Optics*, 6th ed. Oxford: Pergamon Press, 1980. Chapters III and IV.
2. Hecht, E., and Zajac, A. *Optics*. Reading: Addison-Wesley, 1974. Chapters 2 and 3.
3. Klein, M. V. *Optics*. New York: John Wiley & Sons, 1970. Chapters 4 and 5.
4. R. A. Serway and J. W. Jewett, Jr., *Physics for Scientists and Engineers with Modern Physics*. Belmont, CA: Brooks/Cole-Thomson, 2004. Chapter 36.